



***ELECTRONIC LOCK
INSTALLATION GUIDE
FOR MODEL 9100 CASH DISPENSERS***

Version 2.0

TDN 07102-00044B 08/2002

CORPORATE HEADQUARTERS:

522 E. Railroad Street
Long Beach, MS 39560
PHONE: (228) 868-1317
FAX: (228) 868-0437

RMA (RETURN MATERIAL AUTHORIZATION)

RETURN ADDRESS:

21405 B Street
Long Beach, MS 39560

COPYRIGHT NOTICE

Copyright © 2002 Triton Systems of Delaware, Inc. All rights reserved. No part of this publication may be reproduced, transmitted, transcribed, stored in a retrieval system, or translated into any human or computer language, in any form, by any means whatsoever, without the express written permission of Triton Systems. DOVER and the DOVER logo are registered trademarks of Delaware Capital Formation, Inc., a wholly-owned subsidiary of Dover Corporation.

ELECTRONIC LOCK INSTALLATION

MODEL 9100 CASH DISPENSER

Mechanical Lock Removal Procedure

Before the electronic lock assembly can be installed the existing mechanical combination lock must be removed. Follow these steps to remove the existing mechanical lock:

1. Disconnect power to the unit and open the security container door by lifting up on the door handle and swinging the door outward.

Note that the door handle and cabinet lock bar is held in the raised position by a latching catch mechanism on the rear of the door, as shown here:



Figure 1. Latch catch closed, holding lock bar in raised (unlocked) position.

Allow the lock bar to stay in this position. You will be directed to manually release the latch catch to test the operation of the electronic lock in a later step.

2. Remove the two screws that attach the deadbolt cover to the deadbolt and remove the cover.
3. Remove the brass shaft key located in the center of the spindle by pulling directly out on it with a pair of pliers (see Figure 1). Unscrew the outer combination dial from the black spindle wheel and remove both the dial and the wheel from the lock assembly.

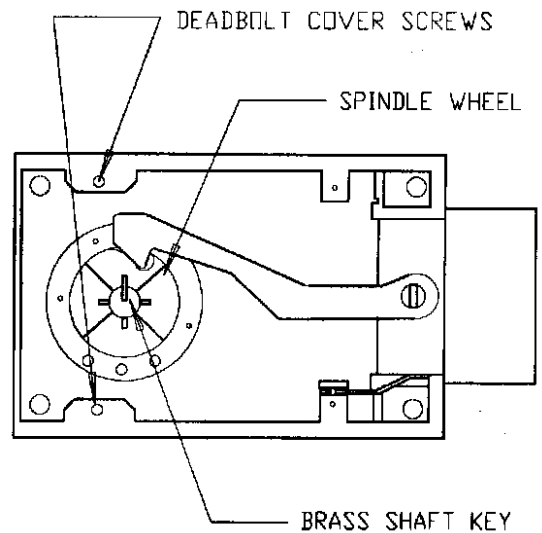

Figure 2 Mechanical combination lock (cover removed).

4. Remove the four screws that attach the deadbolt assembly to the inside of the door and remove the deadbolt assembly.
5. Remove the two screws that attach the dial plate to the cabinet door and remove the dial plate.

ELECTRONIC LOCK INSTALLATION

MODEL 9100 CASH DISPENSER

Electronic Lock Assembly Diagram

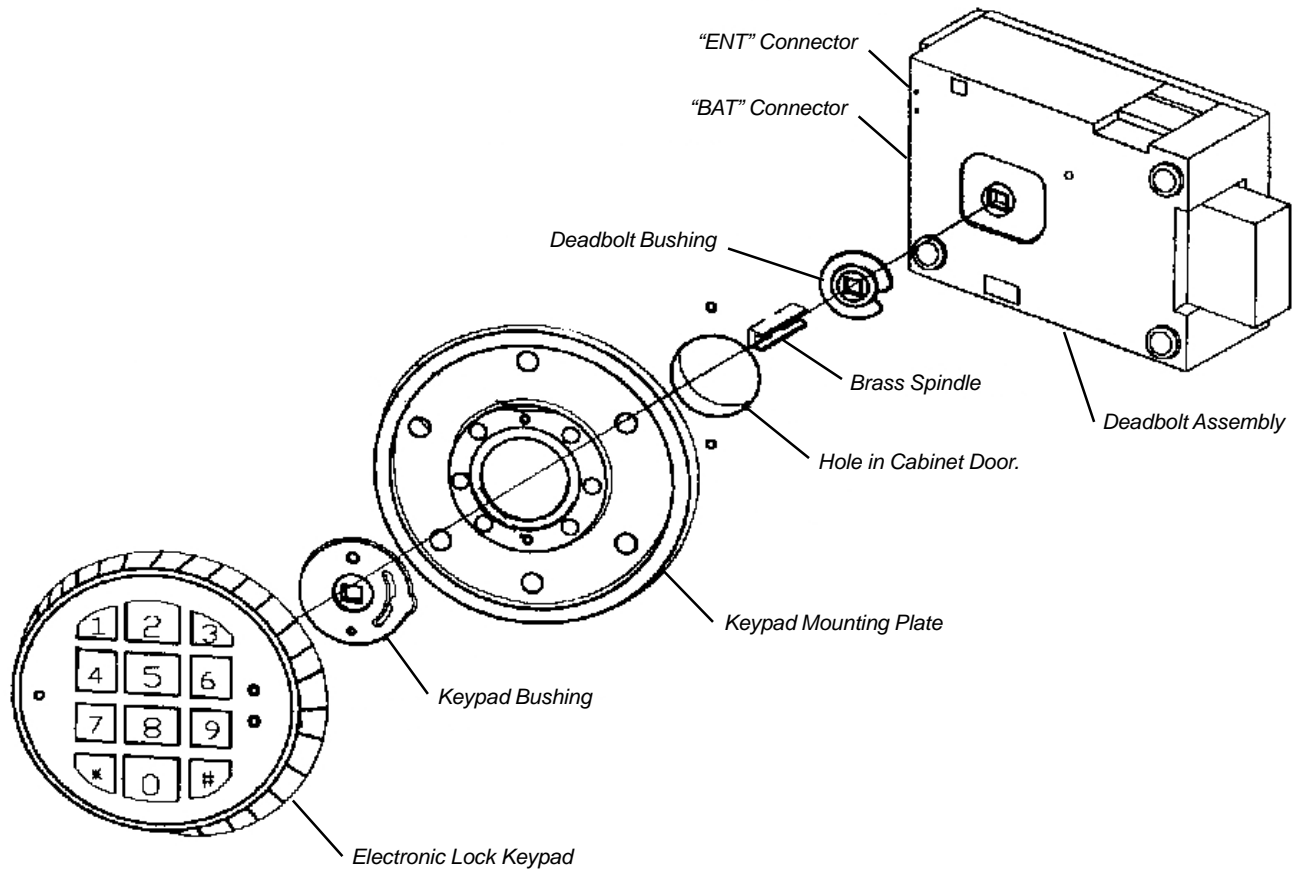

Figure 3. Electronic lock components.

ELECTRONIC LOCK INSTALLATION

MODEL 9100 CASH DISPENSER

Electronic Lock Installation Procedure

After removing the mechanical lock, follow these steps to install the electronic combination lock:

1. Apply a small amount of Loctite to the threads of the included **#8-32 shoulder screws**. Attach the **keypad mounting plate** to the cabinet door using the two shoulder screws.

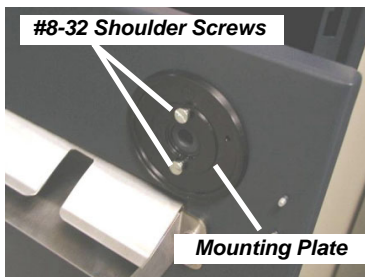

Figure 1. Attach Electronic Lock Mounting Plate.

2. Place the 1-inch long **brass spindle** into the back of the **Electronic Lock Keypad** as shown below. Make sure the **cable** is positioned in the **channel** on the brass spindle. Slide the **keypad bushing** over the cable and the spindle so that it fits flat on the back of the keypad.

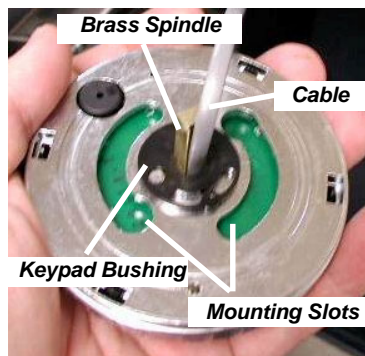

Figure 2. Insert Brass Spindle. Slide Keypad Bushing over spindle and cable. The keypad mounting slots are used to attach keypad to mounting plate.

3. Insert the end of the keypad cable through the hole in the mounting plate and align the shoulder screws with the **mounting slots** in the back of the keypad.



Figure 3. Insert keypad cable through hole in mounting plate. Align large holes in keypad mounting slots with shoulder screws on mounting plate.

4. Align the large holes in the keypad mounting slots with the heads of the shoulder screws. Place the keypad on the shoulder screws and turn it about 10 degrees **clockwise** to lock it onto the mounting plate. **The keypad should turn freely.**

IMPORTANT: If the keypad DOES NOT turn freely, remove the keypad, back the shoulder screws out 1/4-turn, replace the keypad and check the fit again. Continue this process until the keypad turns freely.



Figure 4. Turn 10 degrees clockwise to lock to mounting plate.

ELECTRONIC LOCK INSTALLATION

MODEL 9100 CASH DISPENSER

- Next, slide the **deadbolt bushing** over the end of the keypad cable so that it rests over the brass spindle, flush with the inside of the door.

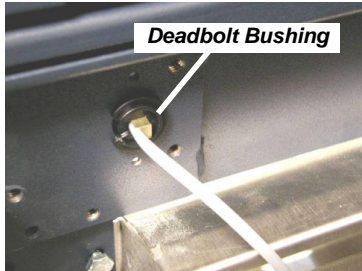

Figure 5. Slide deadbolt bushing over brass spindle.

- IT IS VERY IMPORTANT THAT THE KEYPAD CABLE BE ROUTED EXACTLY AS SHOWN! Failure to do so may result in the lock malfunctioning and thereby locking the cabinet.** The keypad cable must exit through the cutout in the deadbolt bushing, curve over the top of the bushing, and exit on the right, as shown in the figures below.

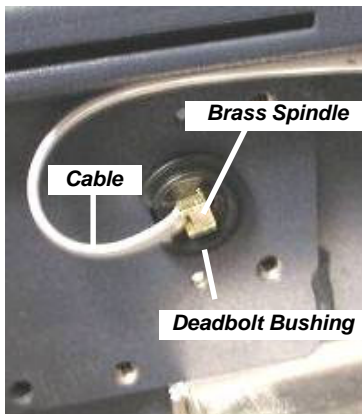

Figure 6. Route cable through cutout in deadbolt bushing.



Figure 7. Cable curves over top of bushing and exits to the right, as shown.

- To install the lock (deadbolt assembly), insert the deadbolt through the cutout in the sliding locker bar. Next, align the brass spindle so that it falls into the square cutout located on the back of the lock.

Once aligned, the lock should sit flush with the mounting plate. Install the **three mounting screws** to hold the lock in place. Plug the keypad cable into the top connector labeled "ENT" located on the lock.

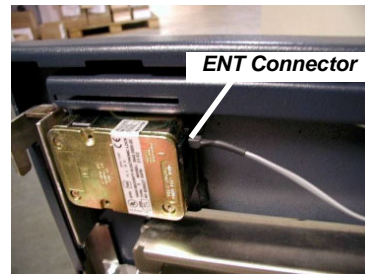

Figure 8. Install Lock. Plug Cable into ENT connector on lock.

- Peel off the adhesive backing on the **battery box** and attach it to the inside of the door. **NOTE:** For better adhesion, clean the area of the door with alcohol prior to attaching the battery box.

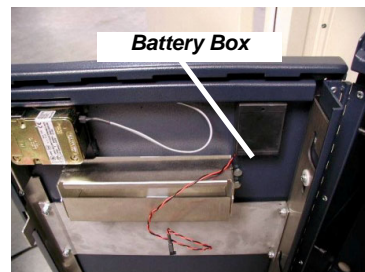

Figure 9. Attach battery box to inside of door.

ELECTRONIC LOCK INSTALLATION

MODEL 9100 CASH DISPENSER

9. Plug the end of the battery cable lead into the lower receptacle on the lock marked **BAT**.

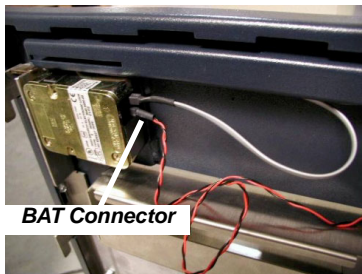

Figure 10. Plug Battery cable into BAT connector on lock.

10. Attach two **tye wrap clips** on to the rear of the door as shown. Loop up the excess cables and attach them in place to the clips using two **tye wraps**.

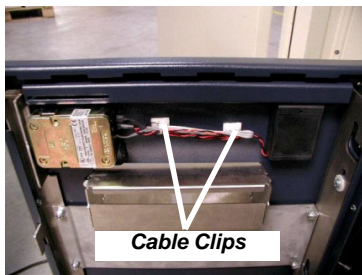

Figure 11. Loop excess lengths of cables and secure in place using tye wrap clips and tye wraps.

11. Place the **lock bracket back** onto the back of the lock and attach using the **1/4-inch bolt**. If there is a label on the back of the lock bracket warning the user about proper combination settings, remove the label. The label only applies to mechanical locks.

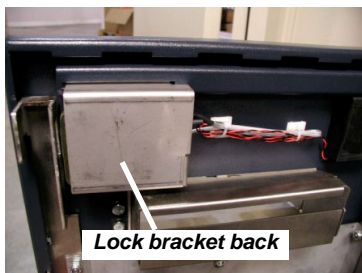

Figure 12. Attach lock bracket using 1/4-inch bolt.

12. **TEST THE LOCK THOROUGHLY BEFORE CLOSING THE DOOR!** To do this, lift up on the door handle (to relieve pressure on the latch mechanism), then push down on the latch lever to disengage the catch that holds the lock bar in the raised position. Use the door handle to carefully lower the lock bar to its rest (locked) position.

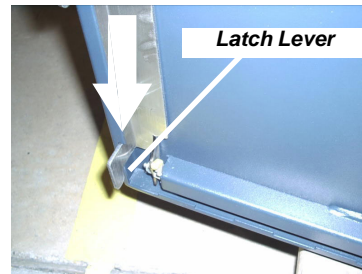

Figure 13. Push down on latch lever to open catch and allow lock bar to lower into locked position.

Next, turn the lock keypad counterclockwise to the locked position. Try to lift the door handle; the handle should not move. Enter **1-2-3-4-5-6** into the keypad and then turn the lock keypad clockwise to unlock the lock. Lift up on the door handle to raise the lock bar. The latch catch should snap into position underneath the lock bar to hold it in the raised (unlocked) position. Release the door handle.

13. It is recommended that you repeat the previous step three times to verify the lock is operating properly.

IMPORTANT!!

BEFORE CLOSING THE CABINET DOOR, LIFT UP ON THE DOOR HANDLE TO ALLOW THE LOCK BAR LATCH TO ENGAGE.

14. See the next section for details on entering and changing the combination and replacing a dead/bad battery.

ELECTRONIC LOCK INSTALLATION

MODEL 9100 CASH DISPENSER

Operating the Electronic Lock

Entering the Combination

The electronic lock combination consists of six digits. Upon arrival, the combination of the lock should already be preset to **1-2-3-4-5-6**.

Follow these steps to enter the combination and open the lock:

1. Enter the preset combination and check for proper operation. After each keypress, the lock will beep. After the final digit has been entered, the lock will beep twice, and the open period will begin.
2. When a valid combination has been entered, the operator will have approximately 3 seconds to open the lock.
3. To open the lock, turn the keypad clockwise.
4. After the lock is opened, the handle may be lifted up and the cabinet door opened.

Lockout Feature

The lock includes a **WRONG TRY PENALTY** lockout feature that prevents entry from unauthorized personnel. This feature performs as follows:

- Entry of four consecutive invalid combinations will disable the lock for 5 minutes.
- During this lockout period, the panel LED will flash every 10 seconds. During this time no other combination entries will be allowed.
- At the end of the lockout period, if two more consecutive invalid combinations are entered, the 5-minute lockout period will restart.

Changing the Combination

WARNING!!

WARNING! NEVER LEAVE THE FACTORY DEFAULT COMBINATION IN THE LOCK! CHANGE THE COMBINATION AS SOON AS POSSIBLE TO HELP PROTECT THE SECURITY OF THE VAULT.

Follow these steps to change the combination:

1. Unlock and open the security cabinet.
2. Repeat the previous step three times to verify the lock is operating properly.
3. Enter six zeros.
4. Enter the current combination. (Initially set at 1-2-3-4-5-6)
5. Enter the new combination twice.
6. The combination is now changed.
7. **TEST THE NEW COMBINATION THOROUGHLY BEFORE CLOSING THE DOOR!** Refer to Step 12 of the procedure on Page 6 for instructions on testing the lock. When directed to enter the combination, use the new combination!
8. Repeat the previous step three times to verify the lock is operating properly.

IMPORTANT!!

BEFORE CLOSING THE CABINET DOOR, LIFT UP ON THE DOOR HANDLE TO ALLOW THE LOCK BAR LATCH TO ENGAGE.

9. Close and lock the security cabinet.

ELECTRONIC LOCK INSTALLATION

MODEL 9100 CASH DISPENSER

Bad Battery/Battery Replacement

If the lock beeps repeatedly while open, or beeps twice and refuses to open, the 9-volt battery, located in the battery box on the inside of the door, is weak or dead and needs to be replaced.

IMPORTANT

If the lock will not operate (i.e. no signal from the panel when a button is pressed) while the door is closed and locked, the battery is dead and the lock must be energized from the two external terminals on the front, right side of the push-button panel.

To energize the lock, connect a 9-volt battery across the external terminals with the negative terminal of the battery facing up. Continue to hold the battery against the terminals as you enter the combination and open the lock.

Follow these steps to replace a battery:

1. Unlock and open the ATM vault door.
2. Pull gently on the front cover of the battery box and slide the cover off.
3. Remove the old battery. Install a new battery and replace the front cover.
4. **TEST THE OPERATION OF THE LOCK BEFORE CLOSING THE DOOR!** Refer to Step 12 of the procedure on Page 6 for instructions on testing the lock. When directed to enter the combination, use the current combinatio!

IMPORTANT!!

BEFORE CLOSING THE CABINET DOOR, LIFT UP ON THE DOOR HANDLE TO ALLOW THE LOCK BAR LATCH TO ENGAGE.

5. Close and lock the ATM vault door.