



ARGO[™]

AUTOMATED TELLER MACHINE INSTALLATION MANUAL

TDN 07103-00338 Rev F. March 22, 2023



CORPORATE HEADQUARTERS:

21405 B STREET
LONG BEACH, MS. 39560
PHONE: (800) 259-6672
FAX: (228) 868-9445

DOCUMENT UPDATES

Date	Description
2/19/13	Original
3/3/13	Added intra-level bracket info
3/25/13	Added installation of security bracket in lower cabinet
4/8/13	Added “Replacing Older Units” info
4/10/15	Added new drawings for ARGO 15 decal area
2/19/16	Added updates for Relative Humidity requirements
8/27/18	Updated temperature and humidity requirements
3/22/2023	Replaced Deep Cabinet Decal Area (Business Hours), page 10. Replace ARGO images page:23. Added Appendix A and B to end of document

INTRODUCTION

The Triton ARGO ATM is a lobby terminal designed for indoor use only. The ARGO line includes models RL1713, RL27XY, and RL63XY. The following sections provide the requirements for installing the ARGO for your particular site location. To assist in preparing your site, a check list is provided of various steps that should be carried out **prior** to the arrival of the ATM.

CONTENTS

PURPOSE/SCOPE/APPLICATION.....	3
REQUIRED PARTS AND TOOLS.....	4
SITE COMPLIANCE.....	4
ENVIRONMENTAL PRECAUTIONS.....	5
TEMPERATURE / POWER / RF INTERFERENCE REQUIREMENTS.....	5
DIMENSIONS.....	6
DEEP CABINET FRONT VIEW / SERVICE AREA DIMENSIONS.....	7
DEEP CABINET SIDE VIEWS.....	8
DEEP CABINET TOPPER / “FOOTPRINT”.....	9
DEEP CABINET DECAL AREA (BUSINESS HOURS).....	10
DEEP CABINET DECAL AREA (VAULT).....	11
SHALLOW CABINET FRONT VIEW / SERVICE AREA DIMENSIONS.....	12
SHALLOW CABINET SIDE VIEWS.....	13
SHALLOW CABINET “FOOTPRINT” / DECAL AREA.....	14
REPLACING OLDER UNITS.....	15
CABINET INSTALLATION.....	16
UNPACK ATM.....	16
MARK/DRILL MOUNTING HOLES.....	17
INSTALL STANDARD ANCHORS/BOLT ATM TO FLOOR.....	18
ROUTE AC POWER AND COMMUNICATION CABLE.....	19
APPENDIX A - SOFTWARE LICENSE AGREEMENT / COMPLIANCE/EMISSIONS STATEMENTS	
APPENDIX B - ATM INSTALLATION FOR ACCESSIBILITY	

PURPOSE

This guide covers the procedure for installing a Triton ARGO ATM with security, stability and ease of operation in mind.

SCOPE

This procedure applies to all service personnel involved in the process of maintaining, converting, or upgrading hardware and software on Triton ATMs nationwide and abroad.

APPLICATION

This Installation Guide provides information, methods and requirements for the physical installation of the Triton ARGO ATM. It contains site preparation, electrical specifications, and cabinet accessibility options that comply with all relevant codes, laws and regulations.

REQUIRED PARTS AND TOOLS

TOOLS REQUIRED	Torque wrench adjustable to at least 60 foot pounds, adjustable crescent wrench or ratchet wrench, hammer, 3/4" (19mm) socket, large flat screwdriver, bubble level, 7/16" socket/box wrench, safety goggles, hearing protection, 1/4" (6mm), 1/2: (12mm) and 9/16" (15mm) carbide-tipped masonry drill bits at least 6" long, 3/4" heavy-duty electric drill (rotary hammer, back support belt, portable vacuum cleaner, wire brush.
*****NOTE:*****	The following kit is required, but not supplied. Call number below for information on availability.
KIT # 06200-00066	Standard anchor kit (four 1/2" x 4 1/2" sleeve-type anchor bolts, 1/2" nuts, 1/2" flat washers)

SITE COMPLIANCE

The site must be prepared by the customer or his agent who is fully conversant with the requirements of installing ATM equipment. The responsibility for ensuring that the site is prepared in compliance with this document remains with the customer.

For information and guidance only, a list is provided in general terms of those matters for which the customer is responsible. The list is not intended to be comprehensive and in no way modifies, alters, or limits the responsibility of the customer for all aspects of adequate site preparation.

1. Location of the equipment and site preparation.
2. Site wiring (power, communication). Ensure access will not be hindered by cabinet placement.
3. Location of other equipment that may cause electrical, electromagnetic or heat induced interference.
4. Make building alterations to meet wiring and other site requirements.
5. Install all communication cables, wall jacks, and associated hardware.
6. Provide and install necessary power distribution boxes, conduits, and grounds.
7. Ensure all applicable codes, regulations, and laws (electrical, building, safety) are adhered to.
8. Ensure the environmental requirements of this unit are met.
9. Install the unit at a height which meets the ADA/DDA/CSA accessibility regulations for the state/country installed. Refer to Appendix B.

SELECTING THE INSTALLATION LOCATION

Choosing the right location for your ATM is very important. Security concerns suggest a location that is away from any door or external access point. Ideally, the terminal should be mounted as close to a back wall as possible. For marketing reasons, however, it may be desirable to locate the terminal near the front where your customers can easily locate it. Wherever you decide to locate the terminal, be sure to follow the recommended procedures for both mounting the terminal and for removing cash when the unit will be unattended.

ENVIRONMENTAL PRECAUTION CHECKLIST



SITE PREPARATION CHECKLIST

1. Select site and design floor plan accordingly.	
2. Ensure all environmental conditions are met.	
3. Establish contractor and vendor schedules.	
4. Check communication line requirements.	
5. Plan installation and accessory needs before starting.	
6. Check floor plan and make necessary alterations.	
7. Install all required electrical fixtures.	
8. Prepare site for communications needs.	
9. Plan operator/training exercises (optional).	
10. Install communication lines and test.	
11. Ensure installation accessories are available.	

TEMPERATURE / HUMIDITY

- The ATM will operate over a range of temperatures and humidity. Generally, these parameters must fall within the following ranges:

Temperature

- 10°C to 40°C
- 50°F to 104°F

Relative Humidity (Non-Condensing)

- 20% - 80%
- (20% - 70% for polymer banknotes)

AC POWER REQUIREMENTS

- Ensure the following AC power requirements are met:

Current (Max)

- 3.3A @ 115 VRMS at 60 Hz

Power Consumption (Idle)

- 0.6A @ 115 VAC at 60 Hz

Voltage

- 90 - 136 VRMS @ 50/60 Hz

Power Consumption (Max Load)

- 396 Watts @ 120VAC

*** IMPORTANT ***

AC power for the terminal should come from a dedicated source with an isolated ground.



DEDICATED TELEPHONE

Dedicated source - The ATM AC power feed will be a dedicated line, to which no other electrical devices are connected. The ATM power line will be wired for a single duplex-style outlet and connected directly to the AC service panel. (No extension cords)

Isolated Ground - An equipment grounding conductor that is insulated from the conduit or raceway and all other grounding points throughout its entire length. The only points of electrical connection will be at the duplex outlet and service panel ends of the line.

****WARNING****

DO NOT APPLY POWER TO THIS TERMINAL UNTIL THE INSTALLATION IS COMPLETE!!

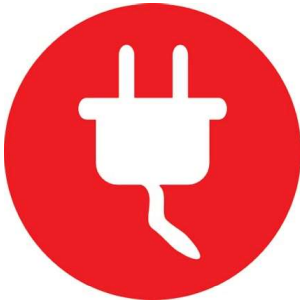

3. Ensure the following telephone-line requirements are met:

- **Dedicated line** - The telephone line servicing the ATM will **not** be a party line or any other shared type connection (fax machines, Point of Sale devices)
- **Proximity to Interference Sources** - The telephone line **must not** be in close proximity to noisy devices that could induce interference into the ATM communications channel. See the next section for additional information on interference sources.

TCP/IP Connection

4. When using TCP/IP communication, ensure:

- **Correct setup** - A clear path of communication has been set up for interface with Host/Processor.
- **No firewalls** - There is no security firewall that will prevent communication with the Host/Processor.

RF INTERFERENCE

5. Ensure there are no devices near the terminal that may cause RF interference, such as:

- TVs
- Coolers
- Security devices
- Neon signs
- Devices with compressors or motors.

DIMENSIONS

Dimensions listed comply with US Federal ADA Guidelines. For USA installations, check for additional guidance. For non-USA installations, check regulations relating to the country of install. Dimensions shown in inches and [millimeters].

The ARGO cabinet is one of two basic sizes: deep or shallow cabinet. The shallow cabinet accommodates the MiniMech dispenser and the deep cabinet accommodates all other dispensers.

DEEP CABINET FRONT VIEW

Customer Access Dimensions		
Feature	Height	
1	Top Function Key	47 5/16" [1202mm]
2	#5 Key (Main Keypad)	36 1/2" [928mm]
3	Card Reader	39 1/8" [994mm]
4	Receipt Printer	38 5/16" [974mm]
5	Bill Tray	25 5/8" [651mm]

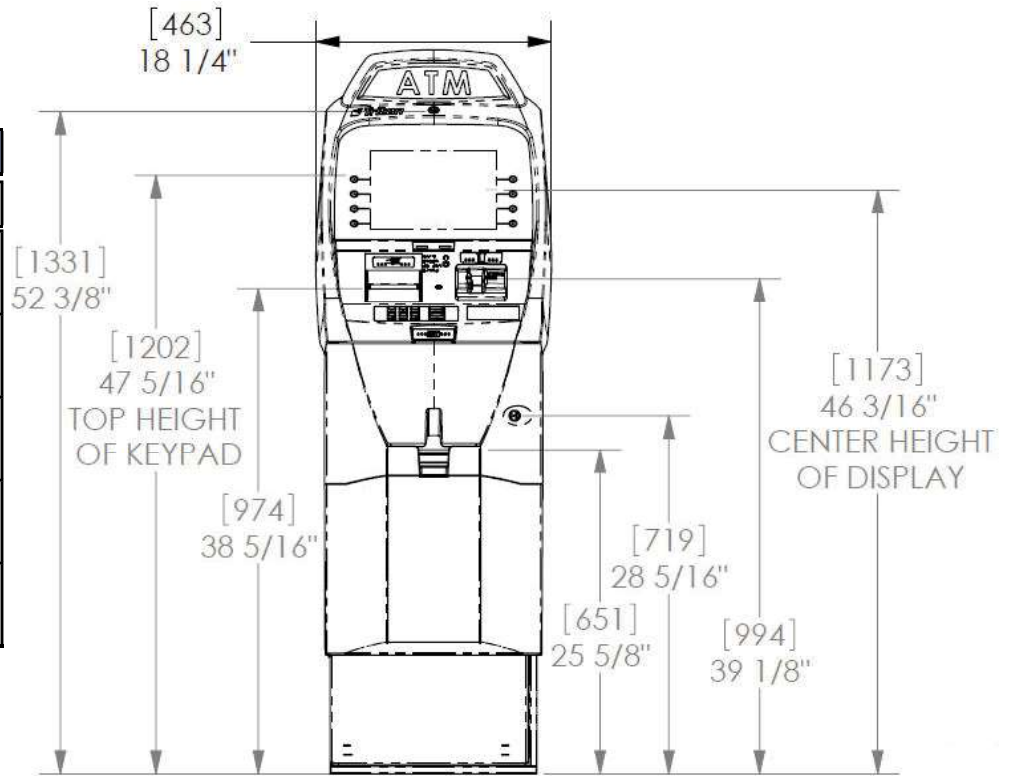

DEEP CABINET SERVICE AREA DIMENSIONS

2" [51] clearance around cabinet sides and rear

Dimensions Shown in inches/millimeters		
Dimension	Business Hours	Vault (Lvl 1)
A	20 1/8" [510]	20 1/8" [510]
B	27 7/8" [708]	28 1/4" [718]
C	20 5/16" [516]	20 1/4" [514]
D	12 3/4" [324]	14 5/16" [363]
E	29 9/16" [751]	30" [762]
F	22" [559]	22" [559]
G	13" [330]	13" [330]

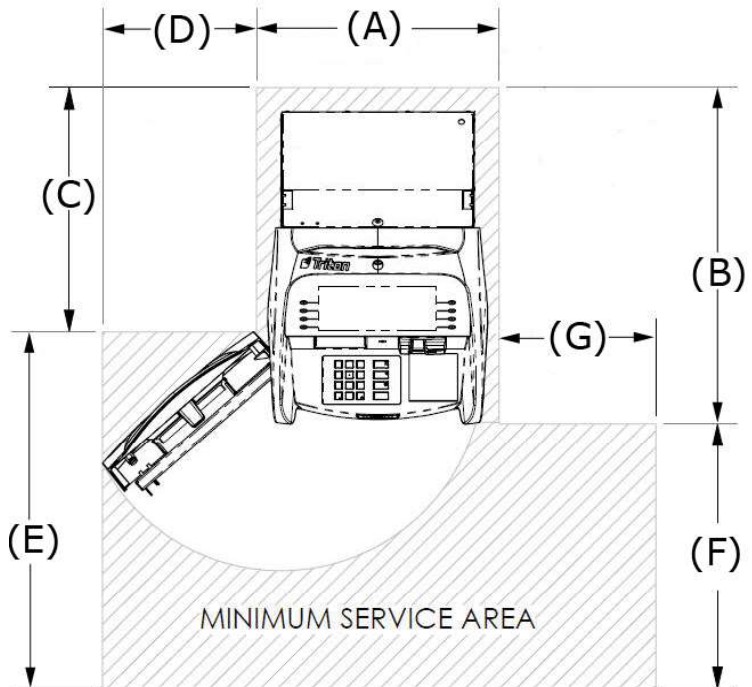

DEEP CABINET DIMENSIONS

SIDE VIEWS

Dimension	Business Hours	Vault (Lvl 1)
H	22 1/8" [562]	22 9/16" [573]
I	25 7/8" [658]	26 1/4" [667]
J	9 11/16" [246]	26 1/4" [667]

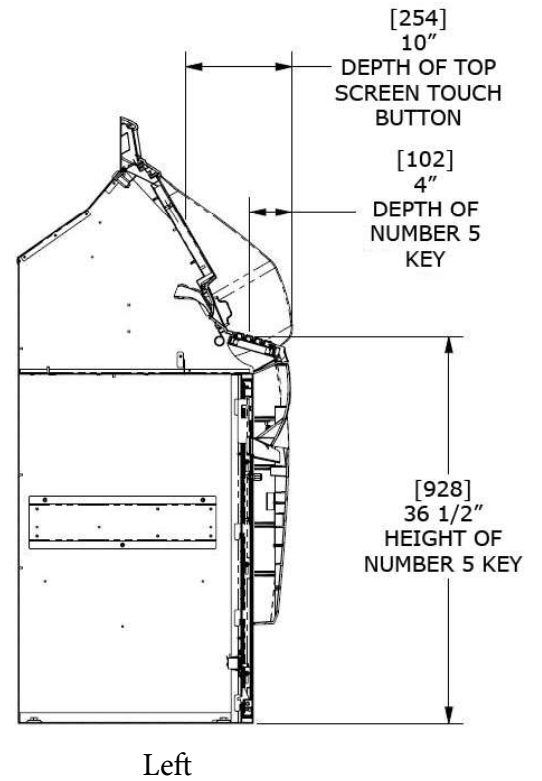
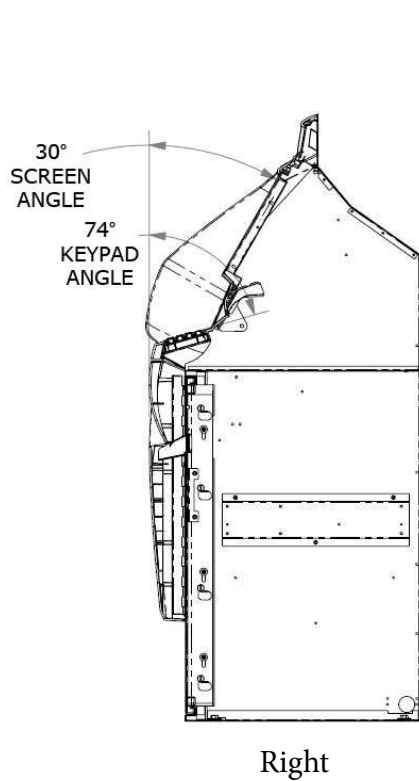
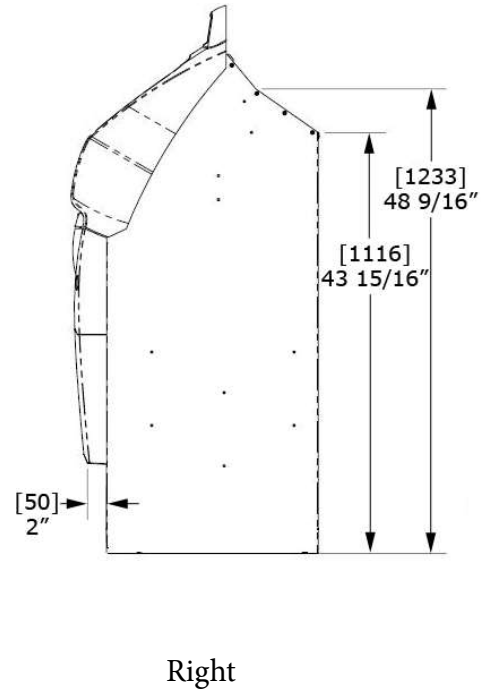
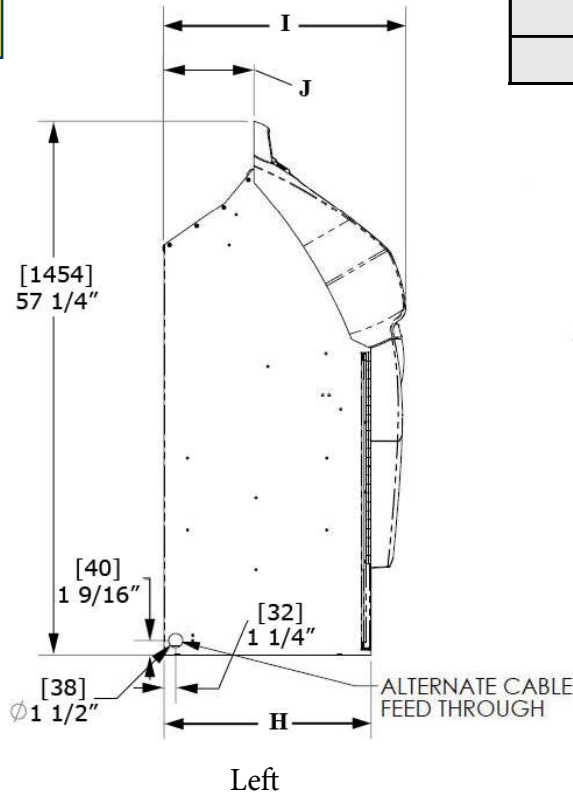

**DEEP
CABINET
TOPPER**

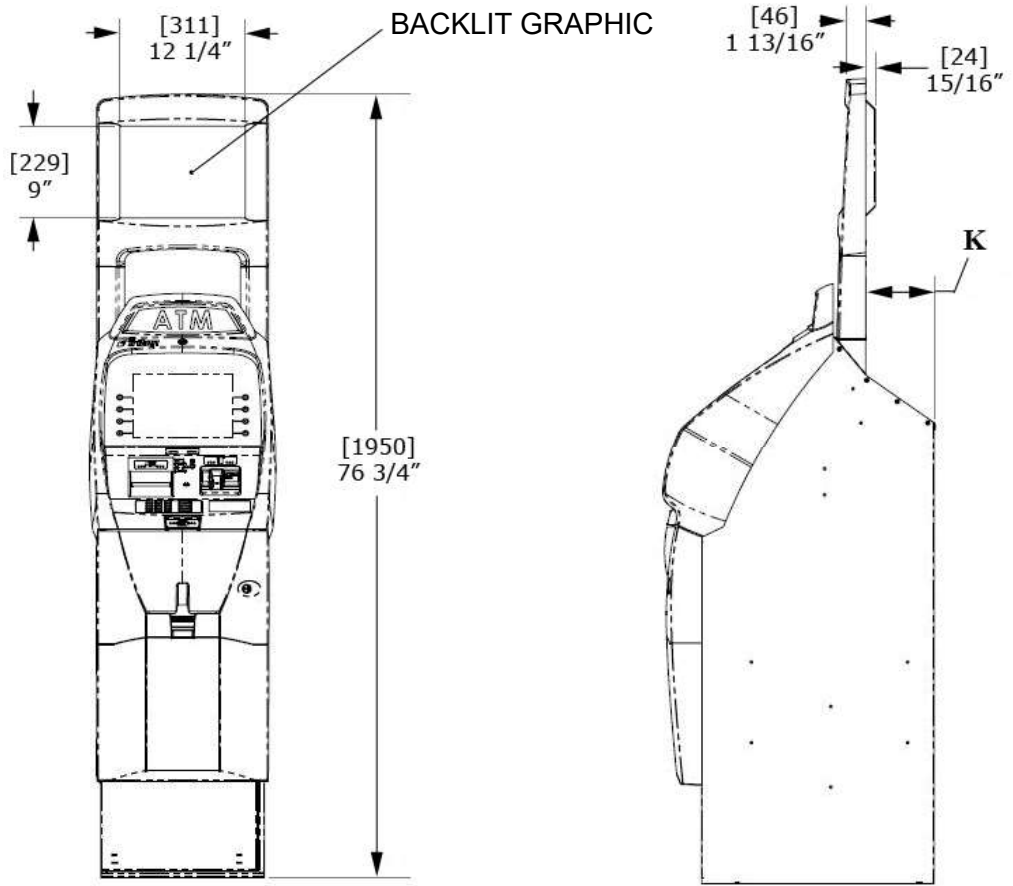

Dimension	Business Hours	Vault (Lvl 1)
K	6 9/16" [167]	7 1/16" [179]

**DEEP CABINET
"FOOTPRINT"**

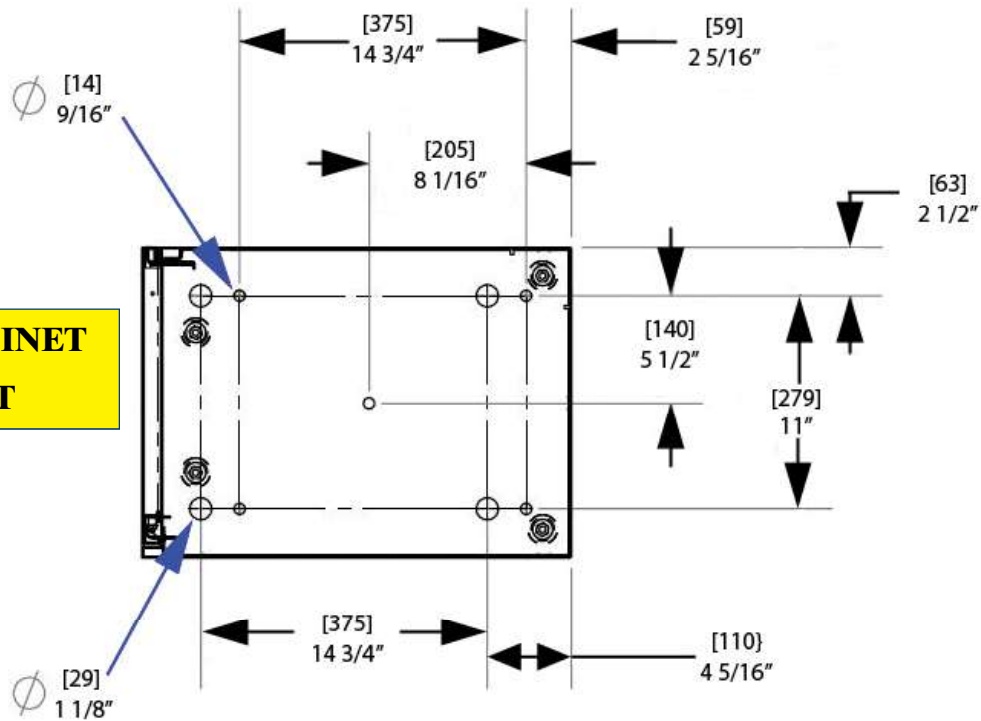

**ATM CABINET
FRONT**

DEEP CABINET DECAL AREA (BUSINESS HOURS)

TRITON MODEL ARGO (SHALLOW) DECAL AREA

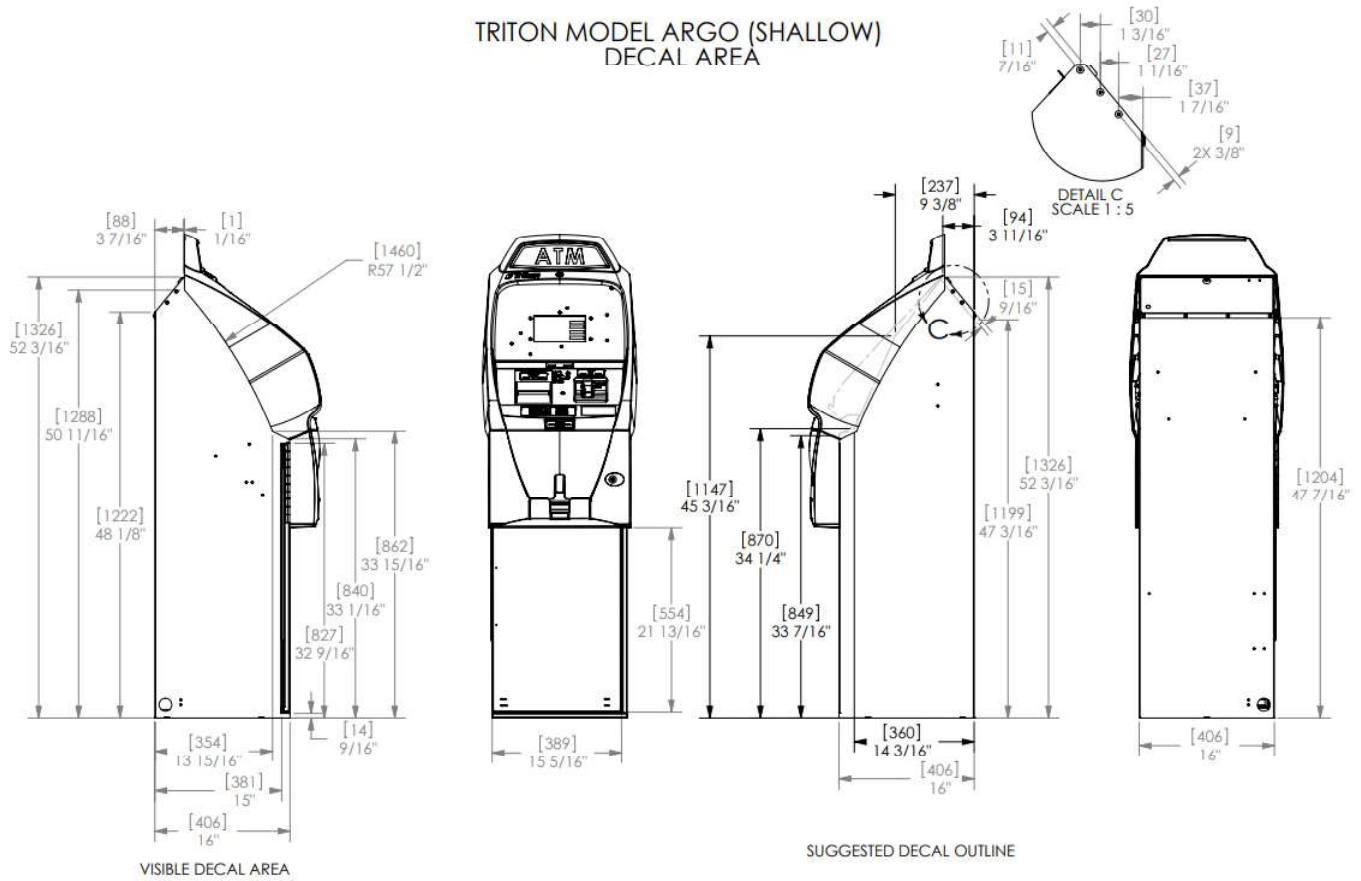

VISIBLE DECAL AREA

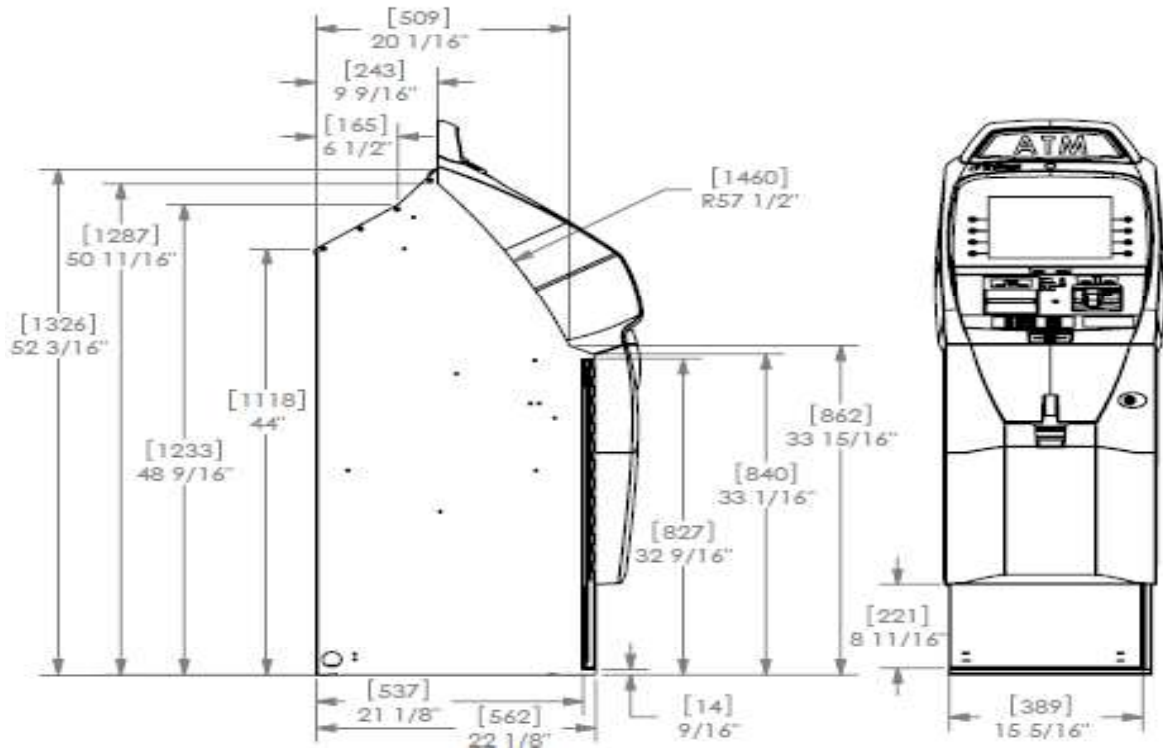

TRITON MODEL ARGO 15 INCH DISPLAY

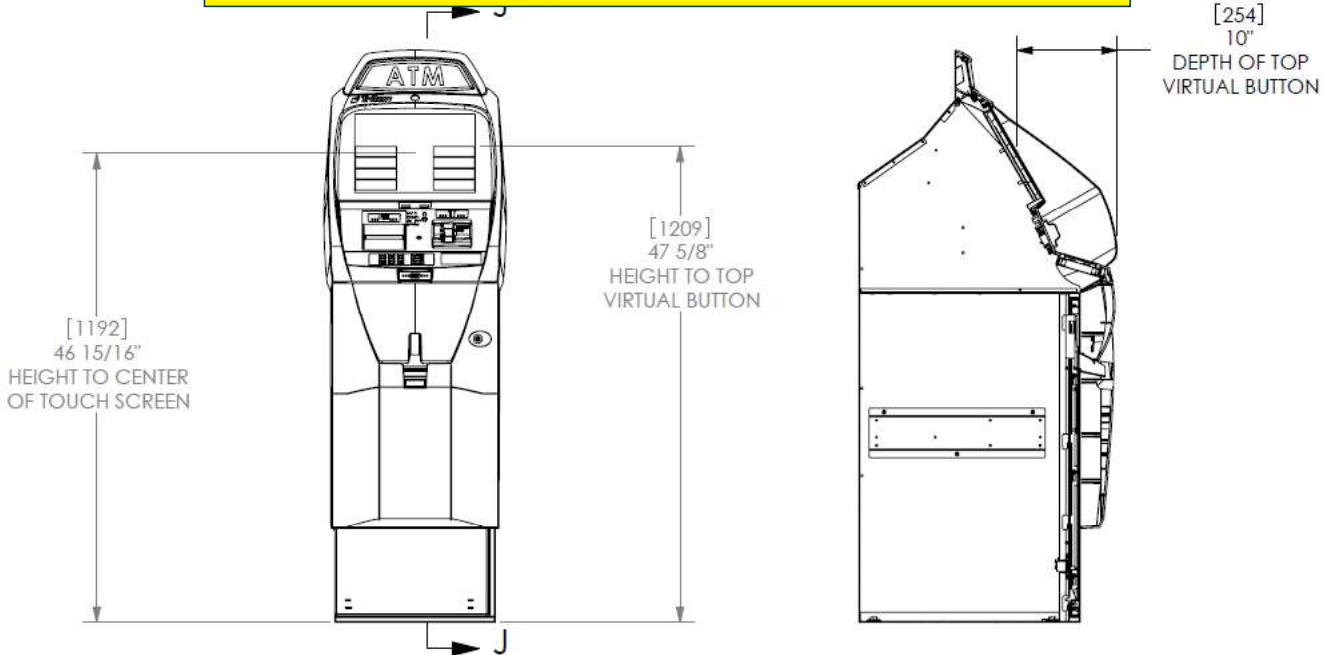

SUGGESTED DECAL AREA

SECTION J-J
SCALE 1 : 11

DEEP CABINET DECAL AREA (VAULT)

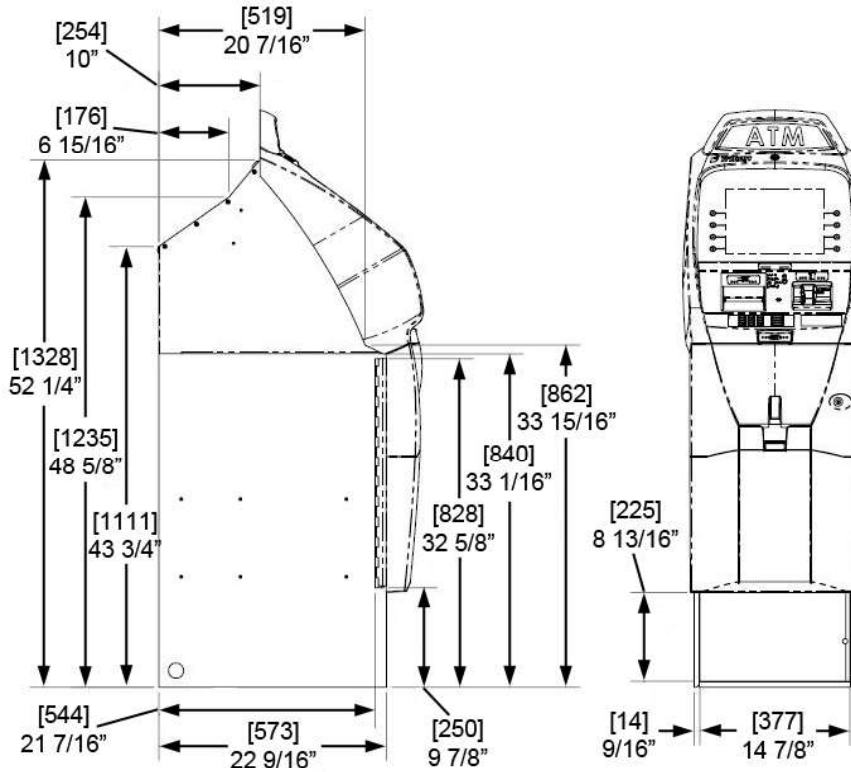

VISIBLE DECAL AREA

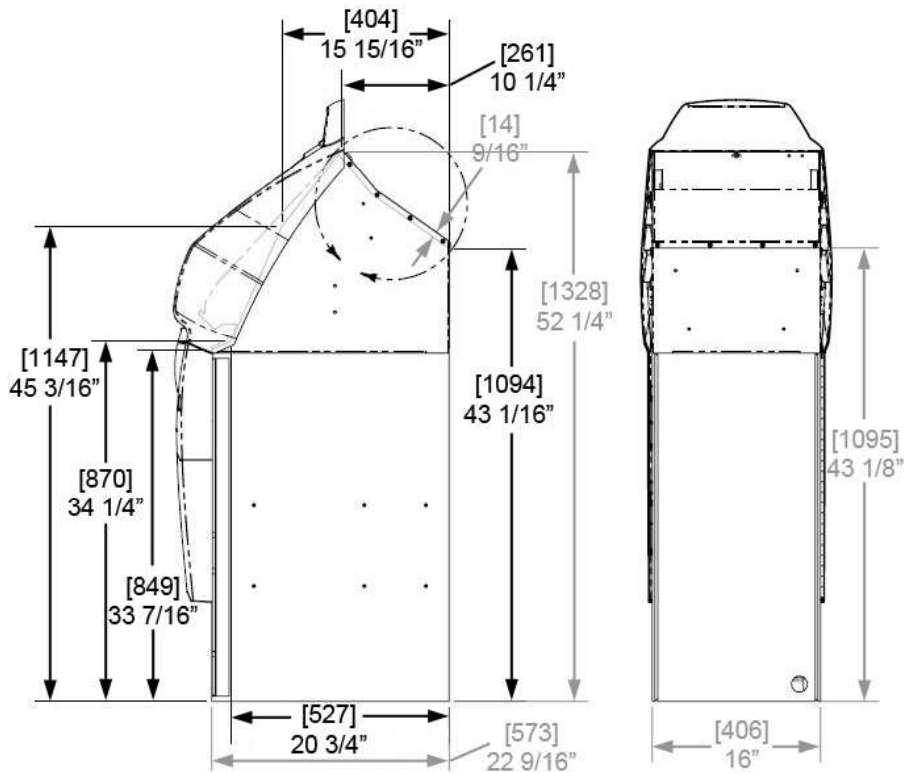

SUGGESTED DECAL AREA

SHALLOW CABINET FRONT VIEW

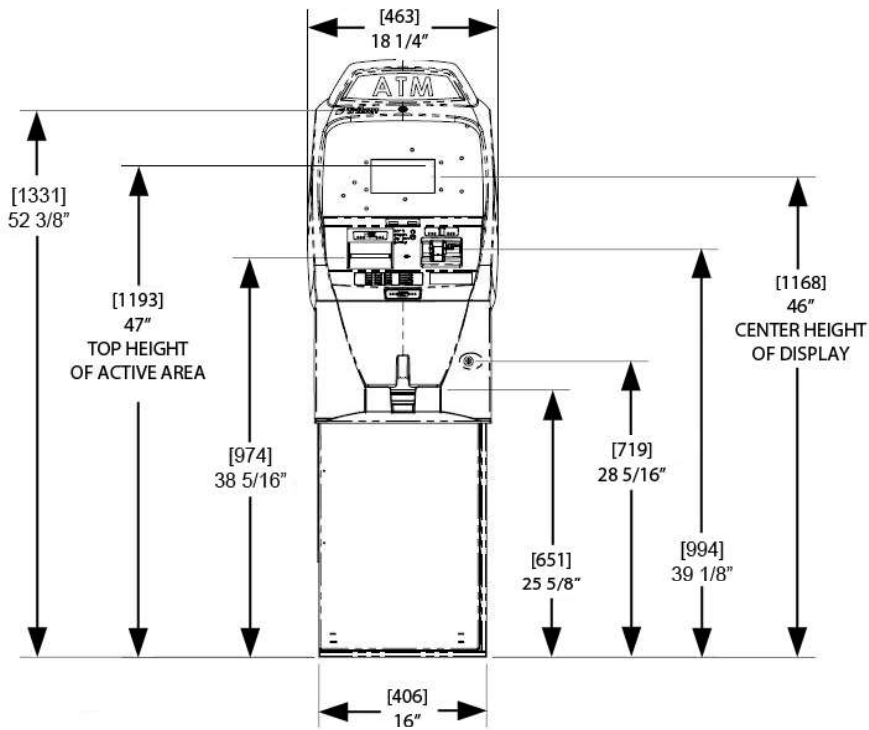

Customer Access Dimensions		
	Feature	Height
1	Top Function Key	47" [1193mm]
2	#5 Key (Main Keypad)	36 1/2" [928mm]
3	Card Reader	39 1/8" [994mm]
4	Receipt Printer	38 5/16" [974mm]
5	Bill Tray	25 5/8" [651mm]

SHALLOW CABINET SERVICE AREA DIMENSIONS

2" [51] clearance around cabinet sides and rear

Dimensions Shown in inches/millimeters	
Dimension	Business Hours
A	20 1/16" [510]
B	21 3/4" [553]
C	16 15/16" [430]
D	2 3/8" [60]
E	26 7/8" [682]
F	22" [559]
G	13" [330]

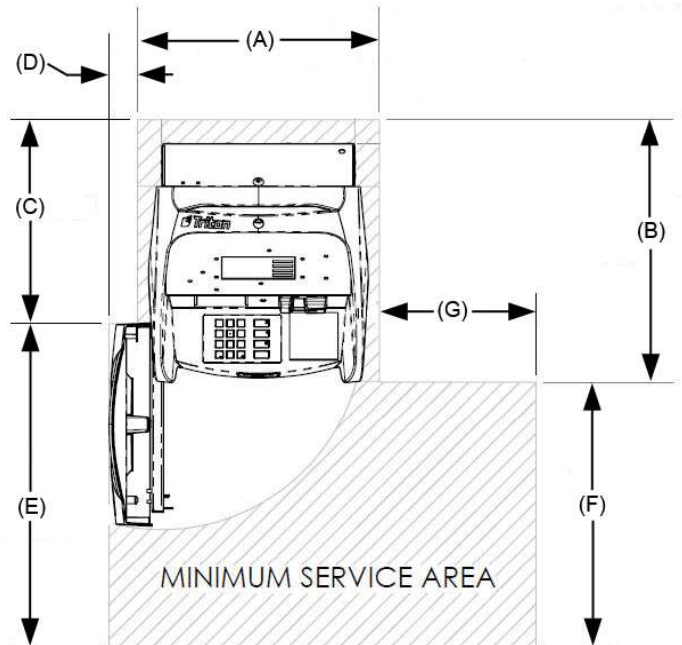

SHALLOW CABINET DIMENSIONS (BUSINESS HOURS)

SIDE VIEWS

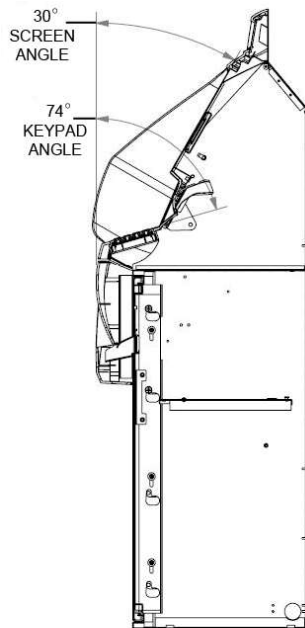
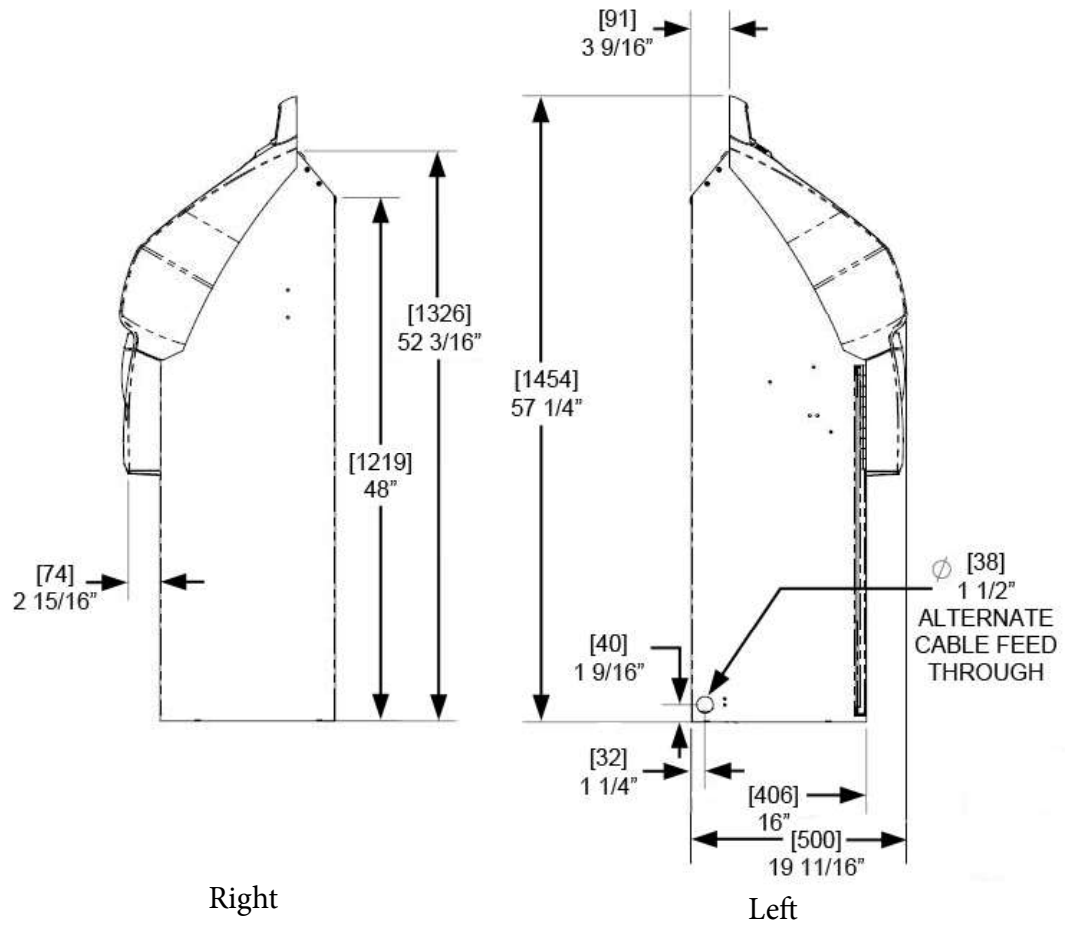

Right

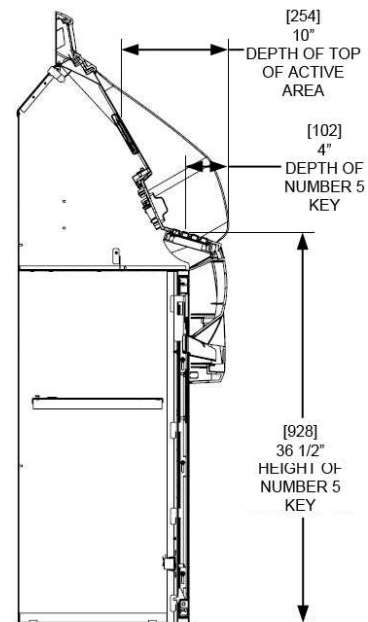

Left

SHALLOW CABINET "FOOTPRINT"

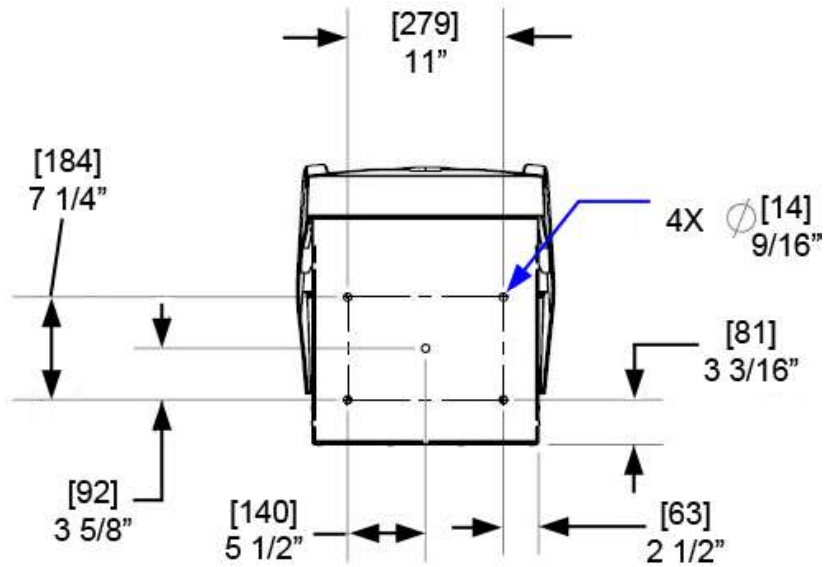

SHALLOW CABINET DECAL AREA (BUSINESS HOURS)

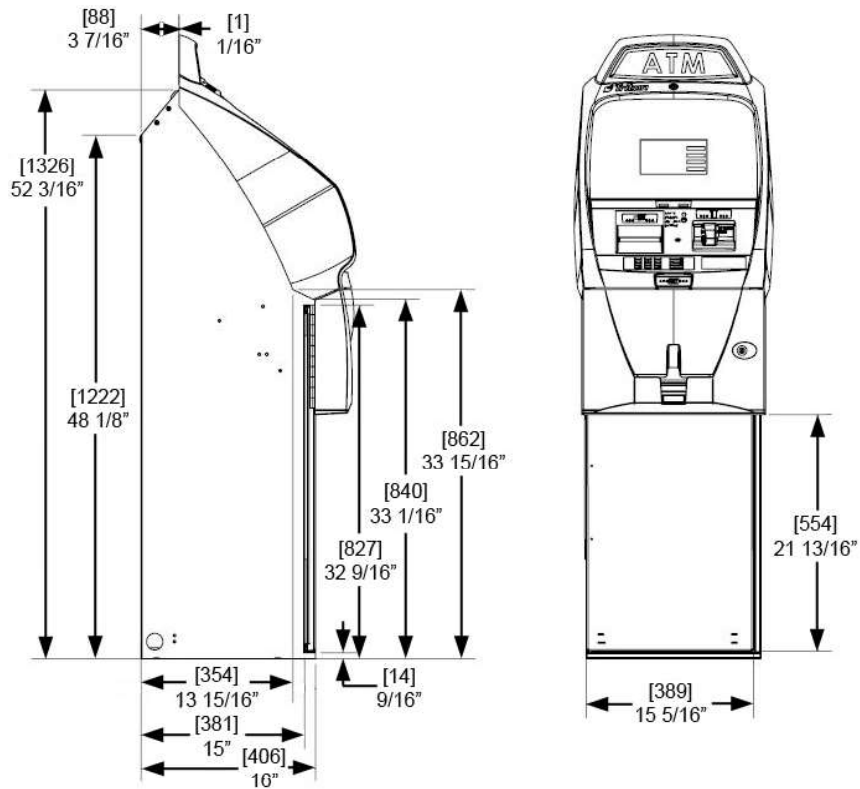

VISIBLE DECAL AREA

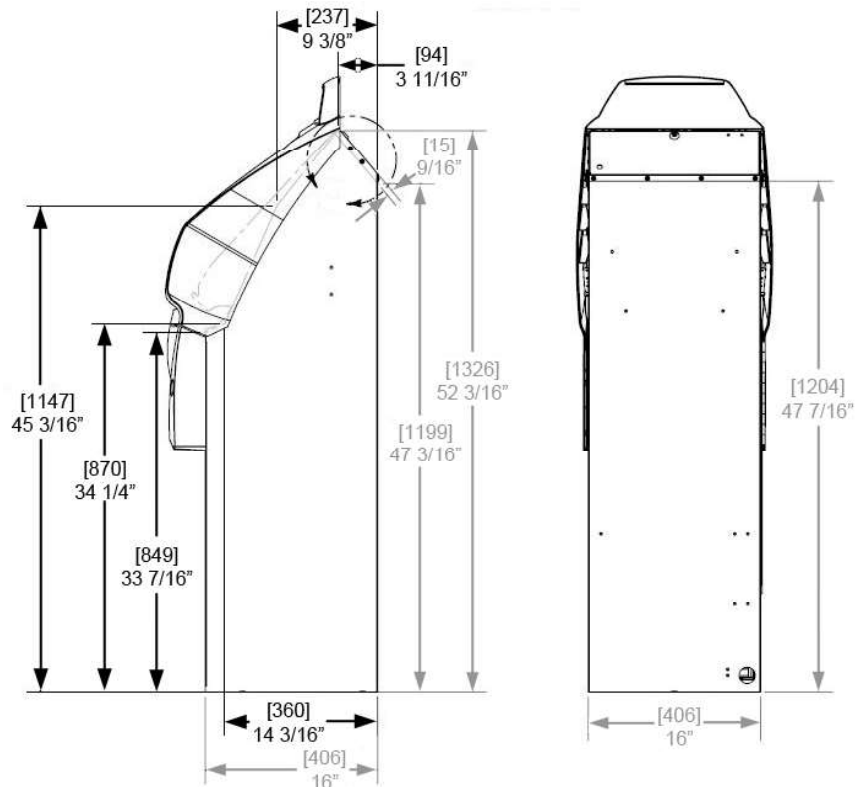

SUGGESTED DECAL AREA

REPLACING OLDER UNITS

When replacing older Triton ATMs with the ARGO, you may be able to use holes already drilled to install the ATM. See the table below for corresponding hole sites.

SHALLOW CABINET ARGO	DEEP CABINET ARGO
<ul style="list-style-type: none"> • 91xx • 9705-9710 (shallow version) • RL2000 (shallow version) • RL1600 	<ul style="list-style-type: none"> • 9100 with SDD (deep version) • 9700-9750 (deep version) • RL5000 • RL2000 (deep version)

CABINET INSTALLATION

The following procedure applies to installing the cabinet assembly using the standard (P/N 06200-00066) anchor kit. The anchor kit **is not** supplied with the unit. Call Triton at 888-7-ATMGURUS for availability.

*** IMPORTANT ***

The ARGO ATM is designed for INDOOR use only!

****WARNING****

DO NOT APPLY POWER TO THIS TERMINAL UNTIL THE INSTALLATION IS COMPLETE!!

UNPACK ATM

1. Carefully inspect the shipping container for any damage and report any damage immediately to the shipping company. Refer to the warranty information in the User Manual for information about reporting shipping damage.
2. Remove the ATM cabinet from the carton by cutting the straps and removing the top of the box.
3. Remove the packing material from inside of the box.
4. Remove the silver key from the white plastic bag attached to the ATM wrapping.
5. Remove the remainder of the box from the ATM if necessary.
6. Remove the wrapping from the ATM.
7. Use the silver key to unlock both the control panel and the fascia door (which conceals the locking mechanism) on the front of the cabinet. Open the fascia door.
8. Lift the handle under the bill chute to open the front enclosure door. If the door is locked, see the sidebar on this page for help in unlocking the electronic or mechanical lock, if applicable.
9. Remove the packing material from inside the vault enclosure and the control panel area.
10. The accessory box is shipped inside the cabinet enclosure. Open and inspect the contents. Check the contents against the enclosed packing list and report any missing parts to Triton.
11. Unbolt the ATM from the shipping pallet. Walk the ATM off of the pallet using caution. The ATM is heavy.

Mark/Drill Mounting Holes

Mark the location of the cabinet mounting holes on the concrete floor. This is accomplished as described below:

1. Move the ATM to the location where it will be installed.

Open the cabinet vault door at least 90° to improve access. Locate the four (4) anchor-bolt holes in the bottom of the cabinet (each corner). Use a felt-tip pen or other marker to carefully mark the center of each of the four corner holes on the floor; these marks will serve as guides for the anchor bolt holes that will be drilled in the next step. Move the ATM aside to provide clear access to the mounting hole marks. Center punch each mark to help align the drill bit.

2. Use a 1/4" [6 mm] diameter carbide-tipped masonry bit to drill four pilot holes at the drilling points marked in the previous step. Drill the pilot holes approximately 1/2" [12 mm] deep into the floor. These holes will help guide the masonry bit that will be used to drill the anchor-bolt holes in the next step.



3. **Standard anchors:** Use a 1/2" [13mm] diameter carbide-tipped masonry bit to drill four holes at least 2-3/4" [70mm] deep into the floor. Be sure to take into account the depth of any floor covering, such as tile or vinyl when gauging the depth of the anchor holes. Make sure the holes are drilled at least 2- 3/4" [70mm] into the concrete floor. (See *Install Standard Anchors/Bolt ATM to Floor* on next page.)
4. **Hole Diameter:** Ensure the holes drilled are not too large in diameter. Test fit the anchor bolts by hand. They should require hammering, **NOT NOW**, and not fall into the hole. Its easier to drill the holes larger now if necessary, than have to move the cabinet and redrill later because they are too big. **DO NOT** be tempted to install the anchors now. It is **VERY** difficult to position the terminal onto the anchors because of the weight.

5. Use a portable vacuum cleaner to remove any dust or debris that may have fallen into the holes during the drilling process.



**INSTALL STANDARD ANCHORS/
BOLT ATM TO FLOOR**

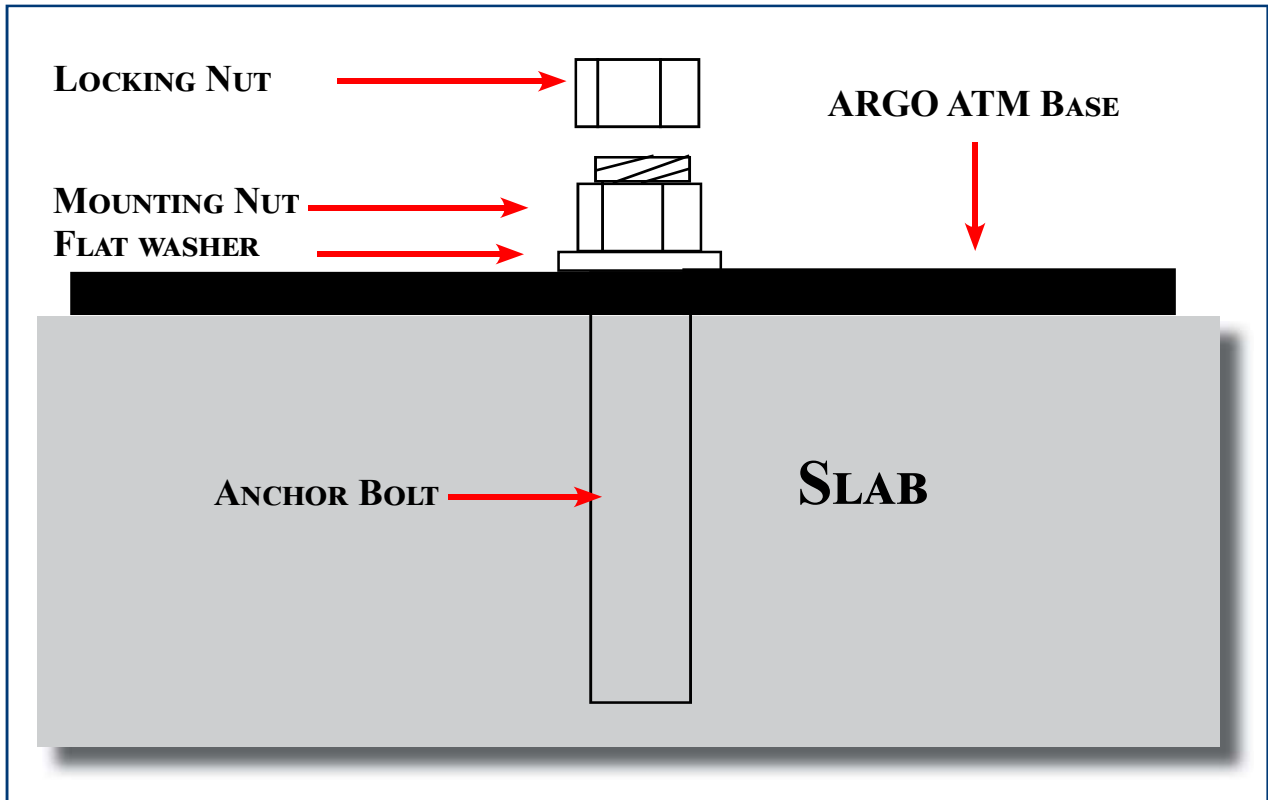

Anchor bolt installation illustration



Anchor Bolt

1. Ensure the mounting location is free of all debris that might cause the cabinet to not be level. Use blower or vacuum to remove any dust or particles.
2. Move the ATM into position for mounting by aligning the base over the four holes drilled in the previous procedure.
3. Place an anchor bolt through the cabinet base and into one of the mounting holes. Use a ball peen hammer to tap the bolt completely into the hole.
IMPORTANT: If the anchor bolt “falls” into the hole without being tapped in, the hole is too large! Move the mounting hole pattern and redrill using smaller holes as necessary to achieve a snug fit.
4. Place a flat washer on the anchor bolt followed by a 1/2” (13mm) nut. Do not tighten fully, allow for leveling.
5. Repeat Steps 3 and 4 for the remaining anchor bolts.

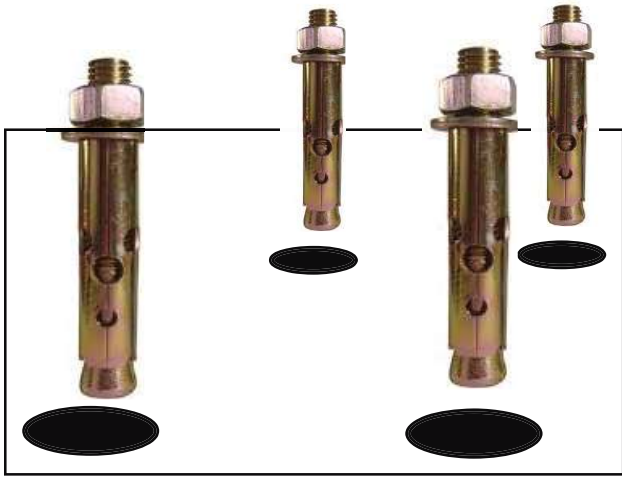

Use anchor bolt in each mounting hole



Hammer bolts snugly into drilled holes

6. Ensure the cabinet is as level as possible given the floor conditions. Use a bubble level to verify this. If a bubble-level is not available, the cabinet can be “rocked” gently from front-to-back and side-to-side to check the need for leveling.
7. Use a torque wrench and 3/4” [19mm] socket to tighten each nut to ***60 foot-pounds (required to establish the maximum pull-out strength of the anchors)***. If a torque wrench is not available, use a ratchet wrench and 3/4” [19mm] socket to tighten the nuts ***three full turns beyond hand tight***. DO NOT overtighten.
8. Once the nuts are tightened as specified in Step 7, ***install a second nut on each bolt, to act as a jam nut, and tighten down firmly.***

ROUTE AC POWER AND COMMUNICATION CABLE

NOTE: Before you start, unlock and open the control panel. Verify that the power switch on the unit’s power supply is in the OFF (0) position. Close the control panel.

Power Outlet Accessibility

Whether you are installing a new AC socket outlet or plan to use an existing outlet to supply power to the ATM, make sure the following requirements are met:

1. The outlet is located near the equipment. Extension cords are not recommended.
2. AC power for the terminal should come from a dedicated source with an isolated ground. The ATM is designed to work on an IT (Isolated-Terra) type power system having phase-to-phase voltage not exceeding 120 or 240 volts.
3. The outlet is easily accessible and will not be blocked once the equipment is installed and anchored.

1. Route the AC power cord and the phone (or Cat-5) cable through either the main or alternate cable access hole at rear corner of unit, (as applicable).
2. Connect the AC power cord and communication cable to their respective facility outlets.
3. Secure/plug the unused access hole with the grommet or plug provided.
4. Install the security bracket. This new feature introduced with the ARGO prevents both people and rodents from accessing the dispenser and internal wiring through the holes at the bottom of the cabinet. The bracket and four (4) nuts are found packaged in the accessory bag that is shipped with the ARGO.

Fit the bracket on the fixed bolts, then use an 11/32" driver to tighten the nuts.

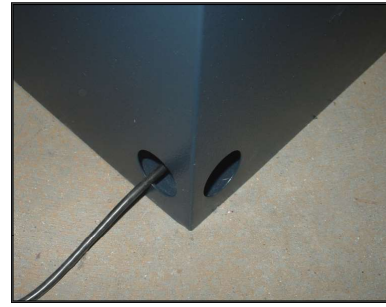

Route wiring and communication harnesses through openings in bottom rear of cabinet and to power supply.



Attach security bracket to lower left corner of cabinet as shown.

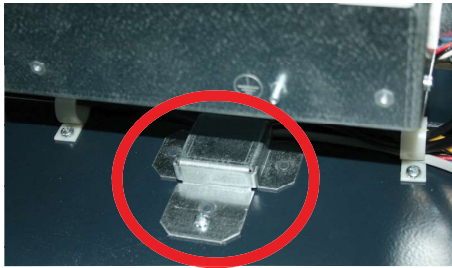

The ARGO unit has an additional security feature with the addition of a special bracket between the upper and lower cabinets to secure cables and wiring running between the cabinets. This is already installed on the ARGO from the factory. One must have access to **both** the upper and lower cabinets in order to add or remove cables/wiring. The bracket has a top screw and three fixed bolts underneath. Unscrew the screw and three nuts to release the bracket.

This unit may be equipped with more than one power cord. **Disconnect All Power Cords prior to Servicing!** For continued fault protection, follow the correct voltage and current ratings when replacing any fuses.

**POWER SUPPLY CORD
SPECIFICATIONS**

For European applications, the power supply cord must conform to the following:

1. Two-conductor with Physical Earth (PE) ground.
2. IEC 320 molded connector on one end and molded plug on the other end.
3. Certified for country of installation.
4. Rated minimum H05VV-F with minimum 0.75 mm² (except where specific countries require 1.0 mm²) conductors.
5. Maximum length: 3 meters.

REFER TO THE USER MANUAL AND CONFIGURATION MANUAL FOR OPERATIONAL INSTRUCTIONS.

NOTE: IT MAY TAKE UP TO 30 SECONDS FOR THE DISPLAY TO ILLUMINATE, AND ANOTHER 15 SECONDS FOR THE OPERATING SYSTEM TO LOAD.



APPENDIX A
SOFTWARE LICENSE AGREEMENT
COMPLIANCE / EMISSION STATEMENTS

**AUTOMATED TELLER MACHINE (“ATM”) SOFTWARE
END-USER AGREEMENT**

IMPORTANT: PLEASE READ CAREFULLY:

BY INSTALLING OR OTHERWISE USING THE ATM, YOU (AS THE OWNER OR LESSEE OF THE ATM). AGREE TO BE BOUND BY THE FOLLOWING TERMS AND CONDITIONS, INCLUDING, WITHOUT LIMITATION, THE WARRANTY DISCLAIMERS, LIMITATIONS OF LIABILITY AND TERMINATION PROVISION WHICH APPLY TO YOUR USE OF THE ATM SOFTWARE CONTAINED IN THIS ATM AND IS HEREBY LICENSED BY TRITON SYSTEMS OF DELAWARE, INC. (“Triton”) TO YOU PURSUANT TO THIS AGREEMENT.

IF YOU DO NOT AGREE TO OR ARE NOT WILLING TO BE BOUND BY THE TERMS AND CONDITIONS OF THIS AGREEMENT, DO NOT INSTALL OR OTHERWISE USE THIS ATM AND PROMPTLY CONTACT YOUR VENDOR. INSTALLING OR OTHERWISE USING THE ATM INDICATES THAT YOU ACCEPT THESE TERMS.

This ATM is manufactured by, and utilizes proprietary software owned by Triton Systems of Delaware, Inc. and/or its suppliers. All right, title and interest in and to all component software installed or embedded in the ATM (“ATM Software”) including all associated intellectual property rights, are and will remain the property of Triton and/or its suppliers.

LICENSE: Triton grants you a limited, nonexclusive license to use the ATM Software but only in connection with the operation of this ATM subject to the terms and restrictions set forth in this License Agreement. You are not permitted to use the ATM Software in any manner not expressly authorized by this License. You acknowledge and agree that ownership of the ATM Software and all subsequent copies thereof regardless of the form or media are held by Triton or its suppliers.

The software is licensed for use on this specific Triton ATM product and may not be used on any other product. Otherwise, the supporting documentation, if any, may be copied only as essential for backup or archive purposes in support of your use of the ATM. You must reproduce and include all copyright notices and any other proprietary rights notices appearing on any copies that you make.

ASSIGNMENT: NO REVERSE ENGINEERING: You may transfer the ATM Software to another party but only in connection with a transfer of all your right, title and interest in and to this ATM and if such party accepts the terms and conditions of this License Agreement. If you transfer the ATM, you must at the same time transfer the supporting documentation, if any, to the same party or destroy any such materials not transferred. Modification, reverse engineering, reverse compiling, or disassembly of the ATM and/or the ATM Software is expressly prohibited.

DISCLAIMER OF WARRANTIES AND LIMITATION OF DAMAGES

TO THE EXTENT PERMITTED BY LAW, THIS ATM SOFTWARE, INCLUDING ALL INCORPORATED THIRD PARTY SOFTWARE, AND DERIVATIVES IS PROVIDED, "AS IS". TRITON MAKES NO REPRESENTATIONS WITH RESPECT TO, AND DOES NOT WARRANT THE PERFORMANCE OR RESULTS YOU OR YOUR CUSTOMERS MAY OBTAIN BY USING THE ATM. TRITON SPECIFICALLY DISCLAIMS ANY AND ALL WARRANTIES, EXPRESS, IMPLIED OR STATUTORY, INCLUDING WITHOUT LIMITATION, WARRANTIES OF QUALITY, PERFORMANCE, NONINFRINGEMENT, AND MERCHANTABILITY OR FITNESS FOR ANY PARTICULAR PURPOSE.

TRITON MAKES NO REPRESENTATIONS OR WARRANTIES AND ASSUMES NO OBLIGATIONS TO YOU OR YOUR CUSTOMERS WITH RESPECT TO ANY TRANSACTION OR SERVICES ACCESSED AND/OR UTILIZED IN CONSUMER-INITIATED TRANSACTIONS MADE FROM THIS ATM. IN NO EVENT WILL TRITON, ITS AFFILIATES, DIRECTORS, OFFICERS, EMPLOYEES, AGENTS OR SUPPLIERS BE LIABLE TO YOU UNDER ANY THEORY OF TORT, CONTRACT, STRICT LIABILITY OR OTHER LEGAL OR EQUITABLE THEORY FOR ANY PUNITIVE, CONSEQUENTIAL, INCIDENTAL, SPECIAL OR SIMILAR DAMAGES, INCLUDING ANY LOSS PROFITS OR LOST SAVINGS, EVEN IF A TRITON AGENT OR REPRESENTATIVE HAS BEEN ADVISED OF THE POSSIBILITY OF SUCH DAMAGES, OR FOR ANY CLAIM BY ANY THIRD PARTY.

YOUR SOLE REMEDY AGAINST TRITON FOR DEFECTIVE PERFORMANCE OF THE ATM SOFTWARE WILL BE LIMITED EXCLUSIVELY TO REPAIR OR REPLACEMENT OF THE ATM AND/OR THE ATM SOFTWARE, AT TRITON'S SOLE DISCRETION.

Any warranty pertaining to the ATM, its mechanical components exclusive of the ATM software, shall be governed and controlled by any warranty given to you by Triton in a separate document accompanying this ATM.

The foregoing limitation of liability and exclusion of certain damages will apply regardless of the success or effectiveness of other remedies.

GOVERNING LAW: This License Agreement shall be governed by the laws of the State of Mississippi and by the laws of the United States, excluding their conflicts of laws principles.

SEVERABILITY: In the event any provision of this License Agreement is found to be invalid, illegal or unenforceable, the validity, legality and enforceability of any of the remaining provisions shall not in any way be affected or impaired.

ENTIRE AGREEMENT: This License Agreement and the accompanying Limited Warranty set forth the entire agreement between you and Triton, supersedes all prior agreements, whether written or oral, with respect to the ATM Software, and may be amended only in writing signed by both parties.

**COMPLIANCE / EMISSION STATEMENTS
DISCLAIMER**

The manufacturer of the Automated Teller Machine (ATM) product(s) described herein makes no representations or warranties, either expressed or implied, by or with respect to anything in this manual, and shall not be liable for any implied warranties of fitness for a particular purpose or for any indirect, special, or consequential damages. Information in this document is subject to change without notice and does not represent a commitment on the part of the manufacturer.

**** CAUTION ****

Changes or modifications not expressly approved by Triton Systems could void the regulatory compliance approval and the warranty. Use of this product in a manner other than those described in this manual may result in personal injury!

**EMISSIONS (EMI)
(US Requirements)**

This device complies with Part 15 of the FCC rules. Operation is subject to the following two (2) conditions:

- 1) This device may not cause harmful interference.
- 2) This device must accept any interference received, including interference that may cause undesired operation.

NOTE:

This equipment has been tested and found to comply with the limits for a Class A digital device pursuant to Part 15 of FCC rules. These limits are designed to provide reasonable protection against harmful interference when the equipment is operated in a commercial environment. This equipment generates, uses, and can radiate radio frequency energy and, if not installed and used in accordance with the instruction manual, may cause harmful interference to radio communications. Operation of this equipment in a residential area is likely to cause harmful interference in which case the user will be required to correct the interference at his own expense. Changes or modifications to this unit not expressly approved by the party responsible for compliance could void the user's authority to operate the equipment.

CANADIAN REQUIREMENTS

This digital apparatus does not exceed the Class A limits for radio noise emissions from digital apparatus set in the Radio Interference Regulations of the Canadian Department of Communications. This Class A digital apparatus complies with Canadian ICES-003.

Le present appareil numerique n'emet pas de bruits radioelectriques dépassant les limites applicables aux appareils numeriques de la Class A prescrites dans le Reglement sur le brouillage radioelectrique edicte par le ministere des Communications du Canada. Cet appareil numerique de la classe A est conforme a la norme NMB-003 Canada.

UK / AUSTRALIA / SOUTH AFRICA REQUIREMENTS

Warning:

This is a Class A product. In a domestic environment, this product may cause radio interference in which case the user may be required to take adequate measures.

APPENDIX B
ATM INSTALLATION FOR ACCESSIBILITY

A Guide to the ADA Guidelines

305. Clear Floor or Ground Space

305.1 General. Clear floor or ground space shall comply with 305.

305.2 Floor or Ground Surfaces. Floor or ground surfaces of a clear floor or ground space shall comply with 302. Changes in level are not permitted.

EXCEPTION: Slopes not steeper than 1:48 shall be permitted.

305.3 Size. The clear floor or ground space shall be 30 inches (760 mm) minimum by 48 inches (1220 mm) minimum.

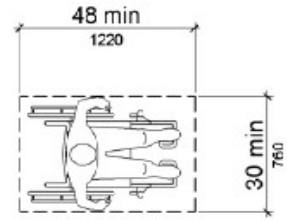

Clear Floor or Ground Space

305.4 Knee and Toe Clearance. Unless otherwise specified, clear floor or ground space shall be permitted to include knee and toe clearance complying with 306.

305.5 Position. Unless otherwise specified, clear floor or ground space shall be positioned for either forward or parallel approach to an element.

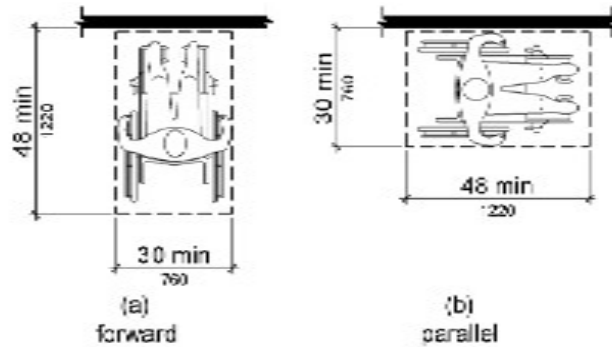

Position of Clear Floor or Ground Space

305.6 Approach. One full unobstructed side of the clear floor or ground space shall adjoin an accessible route or adjoin another clear floor or ground space.

305.7 Maneuvering Clearance. Where a clear floor or ground space is located in an alcove or otherwise confined on all or part of three sides, additional maneuvering clearance shall be provided in accordance with 305.7.1 and 305.7.2.

305.7.1 Forward Approach. Alcoves shall be 36 inches (915 mm) wide minimum where the depth exceeds 24 inches (610 mm).

305.7.2 Parallel Approach. Alcoves shall be 60 inches (1525 mm) wide minimum where the depth exceeds 15 inches (380 mm).

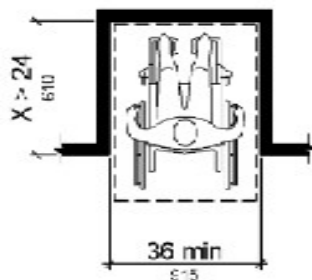

Maneuvering Clearance in an Alcove, Forward Approach

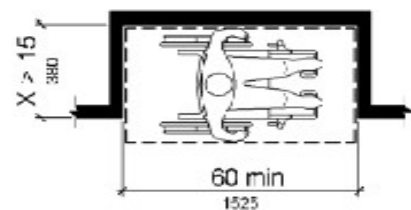

Maneuvering Clearance in an Alcove, Parallel Approach

308. Reach Ranges

308.1 General. Reach ranges shall comply with 308.

308.2 Forward Reach.

308.2.1 Unobstructed. Where a forward reach is unobstructed, the high forward reach shall be 48 inches (1220 mm) maximum and the low forward reach shall be 15 inches (380 mm) minimum above the finish floor or ground.

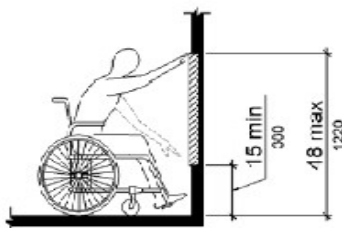

Unobstructed Forward Reach

308.2.2 Obstructed High Reach. Where a high forward reach is over an obstruction, the clear floor space shall extend beneath the element for a distance not less than the required reach depth over the obstruction. The high forward reach shall be 48 inches (1220 mm) maximum where the reach depth is 20 inches (510 mm) maximum. Where the reach depth exceeds 20 inches (510 mm), the high forward reach shall be 44 inches (1120 mm) maximum and the reach depth shall be 25 inches (635 mm) maximum.

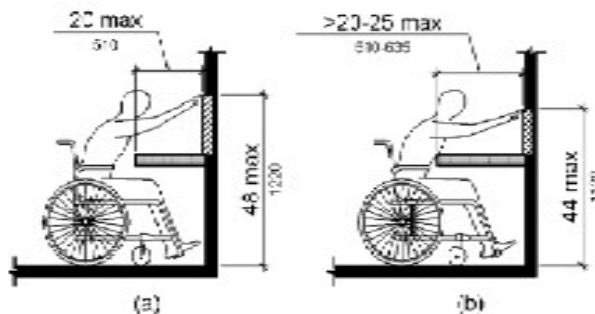

Obstructed High Forward Reach

308.3 Side Reach.

308.3.1 Unobstructed. Where a clear floor or ground space allows a parallel approach to an element and the side reach is unobstructed, the high side reach shall be 48 inches (1220 mm) maximum and the low side reach shall be 15 inches (380 mm) minimum above the finish floor or ground.

EXCEPTIONS:

1. An obstruction shall be permitted between the clear floor or ground space and the element where the depth of the obstruction is 10 inches (255 mm) maximum.
2. Operable parts of fuel dispensers shall be permitted to be 54 inches (1370 mm) maximum measured from the surface of the vehicular way where fuel dispensers are installed on existing curbs.

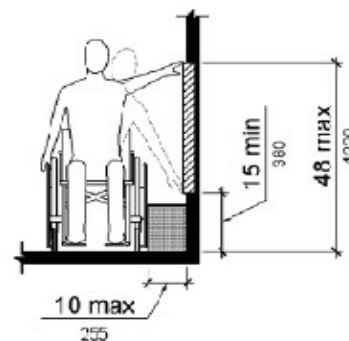

Unobstructed Side Reach

308.3.2 Obstructed High Reach. Where a clear floor or ground space allows a parallel approach to an element and the high side reach is over an obstruction, the height of the obstruction shall be 34 inches (865 mm) maximum and the depth of the obstruction shall be 24 inches (610 mm) maximum. The high side reach shall be 48 inches (1220 mm) maximum for a reach depth of 10 inches (255 mm) maximum. Where the reach depth exceeds 10 inches (255 mm), the high side reach shall be 46 inches (1170 mm) maximum for a reach depth of 24 inches (610 mm) maximum.

EXCEPTIONS:

1. The top of washing machines and clothes dryers shall be permitted to be 36 inches (915 mm) maximum above the finish floor.
2. Operable parts of fuel dispensers shall be permitted to be 54 inches (1370 mm) maximum measured from the surface of the vehicular way where fuel dispensers are installed on existing curbs.

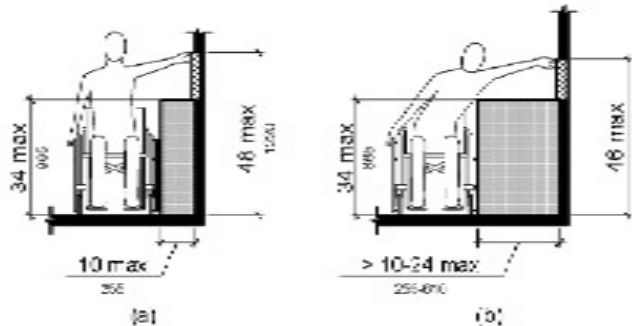

Obstructed High Side Reach

ATM INSTALLATION FOR ACCESSIBILITY

1. This document supersedes all other information provided by Triton for ATM installation for accessibility.
2. Information provided in this manual is based on federal guidelines (ADA Accessibility Guidelines for Buildings and Facilities – ADAAG) as amended through January 1998. You should verify it has not been amended. States may also have accessibility codes. These codes may be more restrictive than the federal guidelines. Please verify this with the state where the ATM is to be installed prior to installation. For state contact information, you may call the ADA information line at 1-800-514-0301.
3. For countries other than the US, please use the guidelines for accessibility for that country.
4. A complete copy of the ADAAG referred to here can be found at <http://www.access-board.gov>. Included in this document is the section of the ADAAG specifically for ATMs. For additional information on floor surfaces and other ADAAG requirements, please see the complete specification.

4.34 Automated Teller Machines.

4.34.1 General. Each automated teller machine machine required to be accessible by **4.1.3 (Accessible Buildings: New Construction)** shall be on an accessible route and shall comply with **4.34 (Automated Teller Machines)**.

4.34.2 Clear Floor Space. The automated teller machine shall be located so that clear floor space complying with **4.2.4 (Clear Floor or Ground Space for Wheelchairs)** is provided to allow a person using a wheelchair to make a forward approach, a parallel approach, or both to the machine.

4.34.3 Reach Ranges.

(1) Forward Approach Only. If only a forward approach is possible, operable parts of all controls shall be placed within the forward reach range specified in **4.2.5 (Forward Reach)**.

(2) Parallel Approach Only. If only a parallel approach is possible, operable parts of controls shall be placed as follows:

APPENDIX B - ATM INSTALLATION FOR ACCESSIBILITY

(a) Reach Depth Not More Than 10 inches (255 mm). Where the reach depth to the operable parts of all controls as measured from the vertical plane perpendicular to the edge of the unobstructed clear floor space at the farthest protrusion of the automated teller machine or surround is not more than 10 inches (255 mm), the maximum height above the finished floor or grade shall be 54 inches (1370 mm).

b) Reach Depth More Than 10 inches (255 mm). Where the reach depth to the operable parts of any control as measured from the vertical plane perpendicular to the edge of the unobstructed clear floor space at the farthest protrusion of the automated teller machine or surround is more than 10 inches (255 mm), the maximum height above the finished floor or grade shall be as follows:

ACCESSIBILITY SPECIFICATIONS			
REACH DEPTH		MAXIMUM HEIGHT	
Inches	Millimeters	Inches	Millimeters
10	255	54	1370
11	280	53 1/2	1360
12	305	53	1345
13	330	52 1/2	1335
14	355	51 1/2	1310
15	380	51	1295
16	405	50 1/2	1285
17	430	50	1270
18	455	49 1/2	1255
19	485	49	1245
20	510	48 1/2	1230
21	535	47 1/2	1205
22	560	47	1195
23	585	46 1/2	1180
24	610	46	1170

(3) Forward and Parallel Approach. If both a forward and parallel approach are possible, operable parts of controls shall be placed within at least one of the reach ranges in paragraphs (1) or (2) of this section.

4) Bins. Where bins are provided for envelopes, waste paper, or other purposes, at least one of each type provided shall comply with the applicable reach ranges in paragraph (1), (2), or (3) of this section.

EXCEPTION: Where a function can be performed in a substantially equivalent manner by using an alternate control, only one of the controls needed to perform that function is required to comply with this section. If the controls are identified by tactile markings, such markings shall be provided on both controls.

4.34.4 Controls. Controls for user activation shall comply with **4.27.4 (Operation)**.

4.34.5 Equipment for Persons with Vision Impairments. Instructions and all information for use shall be made accessible to and independently usable by persons with vision impairments.

(20) Where automated teller machines (ATMs) are provided, each ATM shall comply with the requirements of **4.34 (Automated Teller Machines)** except where two or more are provided at a location, then only one must comply.

EXCEPTION: Drive-up-only automated teller machines are not required to comply with **4.27 (Controls and Operating Mechanisms)** and **4.34.3 (Reach Ranges)**.

4.2.4 Clear Floor or Ground Space for Wheelchairs.

4.2.4.1 **Size and Approach.** The minimum clear floor or ground space required to accommodate a single, stationary wheelchair and occupant is 30 inches by 48 inches (760 mm by 1220 mm) (see Fig.4a). The minimum clear floor or ground space for wheelchairs may be positioned for forward or parallel approach to an object (see Fig. 4b and 4c). Clear floor or ground space for wheelchairs may be part of the knee space required under some objects.

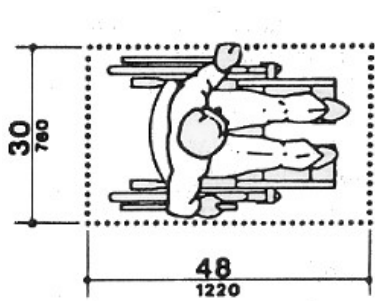

Clear floor space.

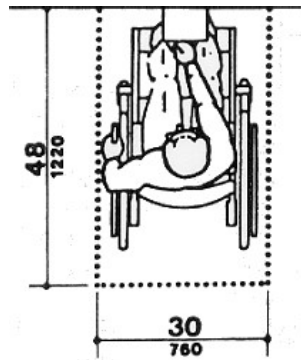

Forward approach.

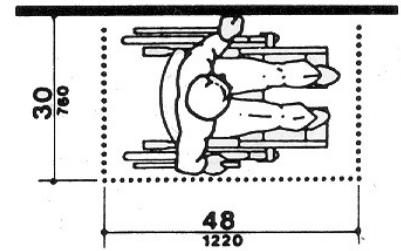

Parallel approach.

4.2.4.2 **Relationship of Maneuvering Clearance to Wheelchair Spaces.** One full unobstructed side of the clear floor or ground space for a wheelchair shall adjoin or overlap an accessible route or adjoin another wheelchair clear floor space. If a clear floor space is located in an alcove or otherwise confined on all or part of three sides, additional maneuvering clearances shall be provided as shown in Fig. 4(d) and 4(e).

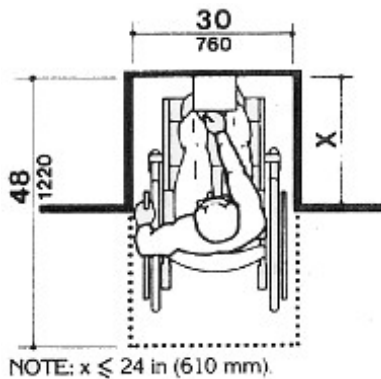

Clear Floor Space in Alcoves.

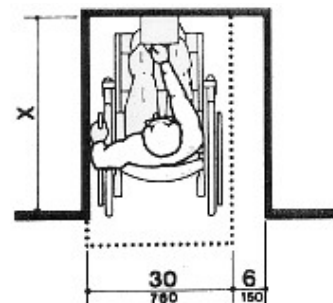

NOTE: If $x > 24$ in (610 mm), then an additional maneuvering clearance of 6 in (150 mm) shall be provided as shown.

Clear Floor Space in Alcove.

For a front approach, where the depth of the alcove is equal to or less than 24 inches (610 mm), the required clear floor space is 30 inches by 48 inches (760 mm by 1220 mm).

For a front approach, if the depth of the alcove is greater than 24 inches (610 mm), then in addition to the 30-inch (760 mm) width, a maneuvering clearance of 6 inches (150 mm) in width is required.

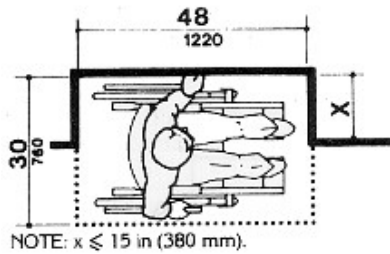

Clear Floor Space in Alcoves.

For a side approach, where the depth of the alcove is equal to or less than 15 inches (380 mm), the required clear floor space is 30 inches by 48 inches (760 mm by 1220 mm).

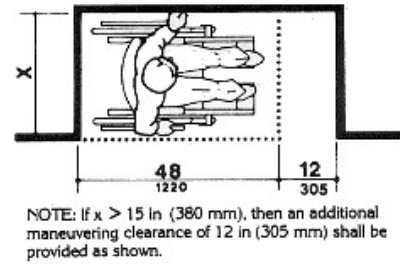

Clear Floor Space in Alcove.

For a side approach, where the depth of the alcove is greater than 15 inches (380 mm), then in addition to the 48-inch (1220 mm) length, an additional maneuvering clearance of 12 inches (350 mm) is required.

4.2.4.3 Surfaces for Wheelchair Spaces. Clear floor or ground spaces for wheelchairs shall comply with **4.5 (Ground and Floor Surfaces)**.

4.2.5 Forward Reach. If the clear floor space only allows forward approach to an object, the maximum high forward reach allowed shall be 48 inches (1220 mm) (see Fig. 5(a)). The minimum low forward reach is 15 inches (380 mm). If the high forward reach is over an obstruction, reach and clearances shall be as shown in Fig. 5(b).

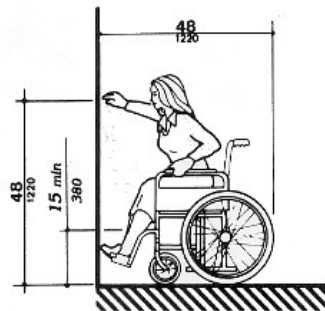

Forward reach, unobstructed.

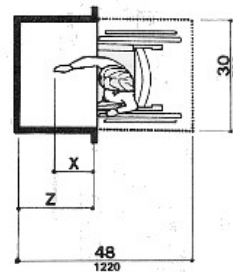
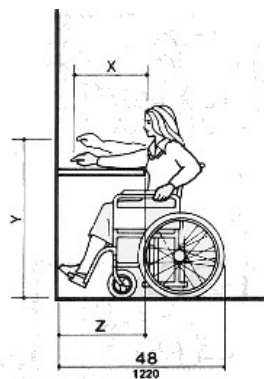
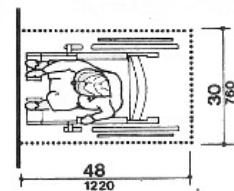

NOTE: x shall be ≤ 25 in (635 mm); z shall be ≥ x. When x < 20 in (510 mm), then y shall be 48 in (1220 mm) maximum. When x is 20 to 25 in (510 to 635 mm), then y shall be 44 in (1120 mm) maximum.

Forward reach, obstructed.

APPENDIX B - ATM INSTALLATION FOR ACCESSIBILITY

4.2.6 Side Reach. If the clear floor space allows parallel approach by a person in a wheelchair, the maximum high side reach allowed shall be 54 inches (1370 mm) and the low side reach shall be no less than 9 inches (230 mm) above the floor (Fig. 6(a) and 6(b)). If the side reach is over an obstruction, the reach and clearances shall be as shown in Fig 6(c).

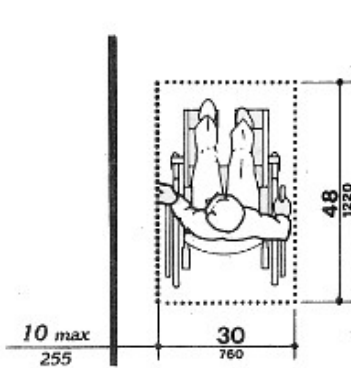

Parallel approach - side reach.

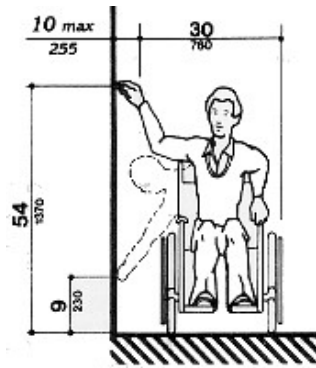

Parallel approach - high/low side reach.

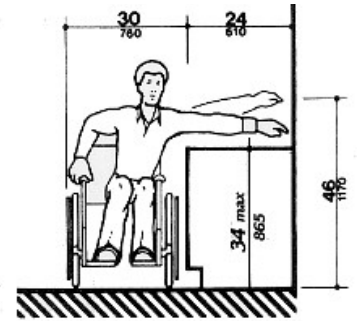

Side reach, obstructed.

Outside Handicap Access Area		
48" (1219 mm) - Across -	30" (762 mm) - Deep -	* Measured from center of Control Panel Fascia *

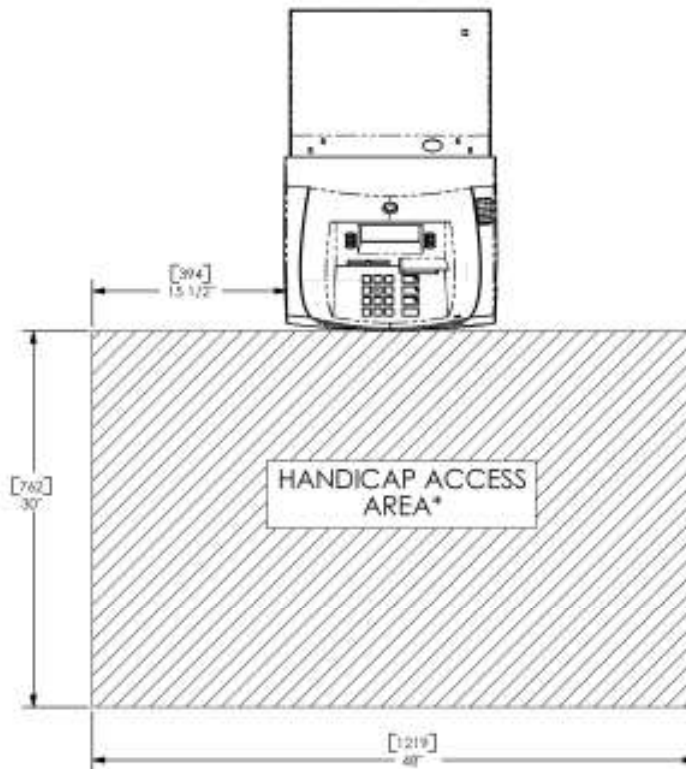

ADA access dimensions